



PADAUK

應廣科技

*RapiDragon* ( **迅龙** )

# PFS123

8bit MTP Type MCU with 12-bit R-Type ADC

Data Sheet

*Version 0.05*

*July 3, 2024*

Copyright © 2024 by PADAUK Technology Co., Ltd., all rights reserved.

6F-6, No.1, Sec. 3, Gongdao 5th Rd., Hsinchu City 30069, Taiwan, R.O.C.

TEL: 886-3-572-8688  [www.padauk.com.tw](http://www.padauk.com.tw)

### **IMPORTANT NOTICE**

**PADAUK Technology reserves the right to make changes to its products or to terminate production of its products at any time without notice. Customers are strongly recommended to contact PADAUK Technology for the latest information and verify whether the information is correct and complete before placing orders.**

**PADAUK Technology products are not warranted to be suitable for use in life-support applications or other critical applications. PADAUK Technology assumes no liability for such applications. Critical applications include, but are not limited to, those which may involve potential risks of death, personal injury, fire or severe property damage.**

**Any programming software provided by PADAUK Technology to customers is of a service and reference nature and does not have any responsibility for software vulnerabilities. PADAUK Technology assumes no responsibility for any issue caused by a customer's product design. Customers should design and verify their products within the ranges guaranteed by PADAUK Technology. In order to minimize the risks in customers' products, customers should design a product with adequate operating safeguards.**

### Table of content

<b>Revision History</b> .....	<b>7</b>
<b>Usage Warning</b> .....	<b>7</b>
<b>1. Features</b> .....	<b>8</b>
1.1. Special Features .....	8
1.2. System Features .....	8
1.3. CPU Features .....	8
1.4. Ordering/ Package Information .....	9
<b>2. General Description and Block Diagram</b> .....	<b>9</b>
<b>3. Pin Assignment and Description</b> .....	<b>11</b>
<b>4. Device Characteristics</b> .....	<b>21</b>
4.1. AC/DC Device Characteristics .....	21
4.2. Absolute Maximum Ratings.....	23
4.3. Typical ILRC frequency vs. VDD.....	23
4.4. Typical IHRC frequency deviation vs. VDD (calibrated to 16MHz).....	23
4.5. Typical ILRC Frequency vs. Temperature .....	24
4.6. Typical IHRC Frequency vs. Temperature (calibrated to 16MHz).....	24
4.7. Typical operating current vs. VDD @ system clock = ILRC/n .....	25
4.8. Typical operating current vs. VDD @ system clock = IHRC/n .....	25
4.9. Typical operating current vs. VDD @ system clock = 4MHz EOSC / n .....	26
4.10. Typical operating current vs. VDD @ system clock = 32KHz EOSC / n.....	26
4.11. Typical operating current vs. VDD @ system clock = 1MHz EOSC / n .....	27
4.12. Typical IO driving current ( $I_{OH}$ ) and sink current ( $I_{OL}$ ) .....	27
4.13. Typical IO input high/low threshold voltage ( $V_{IH}/V_{IL}$ ) .....	29
4.14. Typical resistance of IO pull high/low device .....	30
4.15. Typical power down current ( $I_{PD}$ ) and power save current ( $I_{PS}$ ).....	31
<b>5. Functional Description</b> .....	<b>32</b>
5.1. Program Memory - MTP.....	32
5.2. Boot Procedure .....	33
5.2.1. Timing charts for reset conditions .....	34
5.3. Data Memory - SRAM.....	35
5.4. Oscillator and clock.....	35
5.4.1. Internal High RC oscillator and Internal Low RC oscillator .....	35
5.4.2. Chip calibration.....	35

5.4.3.	IHRC Frequency Calibration and System Clock .....	36
5.4.4.	External Crystal Oscillator .....	37
5.4.5.	System Clock and LVR level .....	39
5.4.6.	System Clock Switching .....	40
5.5.	Comparator.....	41
5.5.1	Internal reference voltage ( $V_{\text{internal R}}$ ).....	42
5.5.2	Using the comparator .....	44
5.5.3	Using the comparator and bandgap 1.20V.....	45
5.6.	VDD/2 LCD Bias Voltage Generator .....	46
5.7.	16-bit Timer (Timer16) .....	47
5.8.	8-bit Timer (Timer2/Timer3) with PWM generation.....	49
5.8.1	Using the Timer2 to generate periodical waveform.....	50
5.8.2	Using the Timer2 to generate 8-bit PWM waveform.....	52
5.8.3	Using the Timer2 to generate 6-bit PWM waveform.....	53
5.9.	11-bit PWM Generator .....	54
5.9.1	PWM Waveform .....	54
5.9.2	Hardware Diagram .....	55
5.9.3	Equations for 11-bit PWM Generator.....	56
5.9.4	PWM Waveforms with Complementary Dead Zones .....	57
5.10.	WatchDog Timer .....	59
5.11	Interrupt .....	60
5.12	Power-Save and Power-Down .....	62
5.12.1	Power-Save mode (“ <i>stopexe</i> ”).....	62
5.12.2	Power-Down mode (“ <i>stopsys</i> ”) .....	63
5.12.3	Wake-up.....	64
5.13.	IO Pins.....	64
5.14.	Reset and LVR.....	66
5.14.1.	Reset.....	66
5.14.2.	LVR reset .....	66
5.15.	Analog-to-Digital Conversion (ADC) module .....	66
5.15.1.	The input requirement for AD conversion .....	67
5.15.2.	Select the reference high voltage .....	68
5.15.3.	ADC clock selection.....	68
5.15.4.	Configure the analog pins.....	68
5.15.5.	Using the ADC.....	69
5.15.6.	How to calculate ADC input voltage $V_{\text{IN}}$ .....	70
<b>6.</b>	<b>IO Registers .....</b>	<b>71</b>

6.1.	ACC Status Flag Register ( <i>flag</i> ), IO address = 0x00 .....	71
6.2.	Stack Pointer Register ( <i>sp</i> ), IO address = 0x02 .....	71
6.3.	Clock Mode Register ( <i>clkmd</i> ), IO address = 0x03 .....	71
6.4.	Interrupt Enable Register ( <i>inten</i> ), IO address = 0x04 .....	72
6.5.	Interrupt Request Register ( <i>intrq</i> ), IO address = 0x05 .....	72
6.6.	Timer16 mode Register ( <i>t16m</i> ), IO address = 0x06.....	73
6.7.	External Oscillator setting Register ( <i>eoscr</i> ), IO address = 0x0a.....	73
6.8.	Interrupt Edge Select Register ( <i>integs</i> ), IO address = 0x0c.....	74
6.9.	Port A Digital Input Enable Register ( <i>padier</i> ), IO address = 0x0d.....	74
6.10.	Port B Digital Input Enable Register ( <i>pbdier</i> ), IO address = 0x0e.....	75
6.11.	Port C Digital Input Enable Register ( <i>pcdier</i> ), IO address = 0x0f.....	75
6.12.	Port A Data Register ( <i>pa</i> ), IO address = 0x10 .....	75
6.13.	Port A Control Register ( <i>pac</i> ), IO address = 0x11 .....	75
6.14.	Port A Pull-High Register ( <i>paph</i> ), IO address = 0x12 .....	76
6.15.	Port B Data Register ( <i>pb</i> ), IO address = 0x13 .....	76
6.16.	Port B Control Register ( <i>pbc</i> ), IO address = 0x14 .....	76
6.17.	Port B Pull-High Register ( <i>pbph</i> ), IO address = 0x15 .....	76
6.18.	Port C Data Register ( <i>pc</i> ), IO address = 0x16 .....	76
6.19.	Port C Control Register ( <i>pcc</i> ), IO address = 0x17 .....	76
6.20.	Port C Pull-High Register ( <i>pcph</i> ), IO address = 0x18 .....	76
6.21.	Port B Pull-Low Register ( <i>pbpl</i> ), IO address = 0x19 .....	77
6.22.	Port C Pull-Low Register ( <i>pcpl</i> ), IO address = 0x1a .....	77
6.23.	ADC Control Register ( <i>adcc</i> ), IO address = 0x20 .....	77
6.24.	ADC Mode Register ( <i>adcm</i> ), IO address = 0x21 .....	78
6.25.	ADC Result High Register ( <i>adcrh</i> ), IO address = 0x22.....	78
6.26.	ADC Result Low Register ( <i>adcrl</i> ), IO address = 0x23.....	78
6.27.	ADC Regulator Control Register ( <i>adcrgc</i> ), IO address = 0x24.....	78
6.28.	MISC Register ( <i>misc</i> ), IO address = 0x26 .....	79
6.29.	Comparator Control Register ( <i>gpcc</i> ), IO address = 0x2b.....	79
6.30.	Comparator Selection Register ( <i>gpcs</i> ), IO address = 0x2c.....	80
6.31.	Timer2 Control Register ( <i>tm2c</i> ), IO address = 0x30 .....	80
6.32.	Timer2 Counter Register ( <i>tm2ct</i> ), IO address = 0x31 .....	80
6.33.	Timer2 Scalar Register ( <i>tm2s</i> ), IO address = 0x32.....	81
6.34.	Timer2 Bound Register ( <i>tm2b</i> ), IO address = 0x33 .....	81
6.35.	Timer3 Control Register ( <i>tm3c</i> ), IO address = 0x34 .....	81
6.36.	Timer3 Counter Register ( <i>tm3ct</i> ), IO address = 0x35 .....	82
6.37.	Timer3 Scalar Register ( <i>tm3s</i> ), IO address = 0x36.....	82
6.38.	Timer3 Bound Register ( <i>tm3b</i> ), IO address = 0x37 .....	82

6.39.	LPWMG0 control Register ( <i>lpwmg0c</i> ), IO address = 0x40 .....	82
6.40.	LPWMG Clock Register ( <i>lpwmgclk</i> ), IO address = 0x41 .....	83
6.41.	LPWMG0 Duty Value High Register ( <i>lpwmg0dth</i> ), IO address = 0x42 .....	83
6.42.	LPWMG0 Duty Value Low Register ( <i>lpwmg0dtl</i> ), IO address = 0x43 .....	83
6.43.	LPWMG Counter Upper Bound High Register ( <i>lpwmgcubh</i> ), IO address = 0x44 .....	83
6.44.	LPWMG Counter Upper Bound Low Register ( <i>lpwmgcubl</i> ), IO address = 0x45 .....	84
6.45.	LPWMG1 control Register ( <i>lpwmg1c</i> ), IO address = 0x46 .....	84
6.46.	LPWMG1 Duty Value High Register ( <i>lpwmg1dth</i> ), IO address = 0x48 .....	84
6.47.	LPWMG1 Duty Value Low Register ( <i>lpwmg1dtl</i> ), IO address = 0x49 .....	84
6.48.	LPWMG2 control Register ( <i>lpwmg2c</i> ), IO address = 0x4C .....	85
6.49.	LPWMG2 Duty Value High Register ( <i>lpwmg2dth</i> ), IO address = 0x4E .....	85
6.50.	LPWMG2 Duty Value Low Register ( <i>lpwmg2dtl</i> ), IO address = 0x4F .....	85
<b>7.</b>	<b>Instructions .....</b>	<b>86</b>
7.1.	Data Transfer Instructions .....	87
7.2.	Arithmetic Operation Instructions .....	91
7.3.	Shift Operation Instructions .....	93
7.4.	Logic Operation Instructions .....	94
7.5.	Bit Operation Instructions .....	96
7.6.	Conditional Operation Instructions .....	97
7.7.	System control Instructions .....	99
7.8.	Summary of Instructions Execution Cycle .....	101
7.9.	Summary of affected flags by Instructions .....	101
7.10.	BIT definition .....	102
<b>8.</b>	<b>Code Options .....</b>	<b>102</b>
<b>9.</b>	<b>Special Notes .....</b>	<b>103</b>
9.1.	Using IC .....	103
9.1.1.	IO pin usage and setting .....	103
9.1.2.	Interrupt .....	104
9.1.3.	System clock switching .....	105
9.1.4.	Watchdog .....	105
9.1.5.	TIMER time out .....	105
9.1.6.	IHRC .....	105
9.1.7.	LVR .....	106
9.1.8.	Programming Writing .....	106
9.2.	Using ICE .....	108

### Revision History

Revision	Date	Description
0.04	2024/03/21	1. Add PFS123-Y24(SSOP24-150mil)
0.05	2024/07/03	1. Updated description of Special Features, Using ICE 2. Adjust the values of the operating temperature range and update the picture 3. Other known details bug correct

### Usage Warning

User must read all application notes of the IC by detail before using it.  
Please visit the official website to download and view the latest APN information associated with it.

<http://www.padauk.com.tw/en/product/show.aspx?num=144&kw=PFS123>

(The following picture are for reference only.)

Feature
Documents
Software & Tools
Application Note

Content	Description	Download (CN)	Download (EN)
APN001	Output impedance of ADC analog signal source		
APN002	Over voltage protection		
APN003	Over voltage protection		
APN004	Semi-Automatic writing handler		
APN005	Effects of over voltage input to ADC		
APN007	Setting up LVR level		
APN011	Semi-Automatic writing Handler improve writing stability		
APN013	Notification of crystal oscillator		
APN019	E-PAD PCB layout guideline		

### 1. Features

#### 1.1. Special Features

- ◆ General purpose series
- ◆ In applications with AC RC step-down power supply or high EFT requirements, the system circuit needs to be modified if necessary to improve the anti-interference capability
- ◆ Operating temperature range: -40°C ~ 85°C

#### 1.2. System Features

- ◆ 3KW MTP program memory (programming cycle at least 1,000 times)
- ◆ 256 Bytes data SRAM
- ◆ One hardware 16-bit timer
- ◆ Two hardware 8-bit timers with PWM generation
- ◆ One set triple 11bit SuLED (Super LED) PWM generators and timers
- ◆ One hardware comparator
- ◆ Bandgap circuit to provide 1.20V reference voltage
- ◆ Up to 14-channel 12-bit resolution R-type\* ADC with one channel comes from internal bandgap voltage  
\*Note: R-Type ADC means Resistive type ADC. Its linearity (INL&DNL), heat stability and power noise rejection would not be as good as the C-Type ADC which is built in the PMS13x series.
- ◆ ADC reference high voltage: external input, internal VDD
- ◆ Max. 18 IO pins with optional pull-high resistor, four of them with additional pull-low resistor
- ◆ Every IO pin can be configured to enable wake-up function
- ◆ Built-in VDD/2 LCD bias voltage generator to provide maximum 5x12 dots LCD display
- ◆ Clock sources: IHRC, ILRC and EOSC (XTAL)
- ◆ For every wake-up enabled IO, two optional wake-up speed are supported: normal and fast
- ◆ 8 selectable levels of LVR reset from 1.8V to 4.0V
- ◆ Two selectable external interrupt pins by code option

#### 1.3. CPU Features

- ◆ 8-bit high performance RISC CPU
- ◆ 90 powerful instructions
- ◆ Most instructions are 1T execution cycle
- ◆ Programmable stack pointer to provide adjustable stack level
- ◆ Direct and indirect addressing modes for data access. Data memories are available for use as an index pointer of Indirect addressing mode
- ◆ IO space and memory space are independent



### 1.4. Ordering/ Package Information

- ◆ PFS123-U06: SOT23-6 (60mil)
- ◆ PFS123-S08: SOP8 (150mil)
- ◆ PFS123-M10: MSOP10 (118mil)
- ◆ PFS123-S14: SOP14 (150mil)
- ◆ PFS123-S16: SOP16 (150mil)
- ◆ PFS123-D16: DIP16 (300mil)
- ◆ PFS123-S20: SOP20 (300mil)
- ◆ PFS123-Y24: SSOP24(150mil)
- ◆ PFS123-H20: HTSOP20 (150mil)
- ◆ PFS123-1J16A: QFN3\*3-16P (0.5pitch)
- ◆ PFS123-1J20A: QFN3\*3-20P

- Please refer to the official website file for package size information : "Package information"

## 2. General Description and Block Diagram

The PFS123 is an MTP-based CMOS 8-bit microcontroller with 8-bit ADC. It employs RISC architecture and all the instructions are executed in one cycle except that some instructions are two cycles that handle indirect memory access.

Up to 3KW MTP program memory and 256 bytes data SRAM are inside. One up to 14 channels 12-bit R-Type ADC is built inside the chip with multiple reference voltage sources selectable. PFS123 also provides four hardware timers: one is 16-bit timer, two are 8-bit timers with PWM generation, and one new triple 11-bit timer with SuLED PWM generation (LPWMG0, LPWMG1 & LPWMG2) are included. PFS123 also supports one hardware comparator and VDD/2 LCD bias voltage generator for LCD display application.

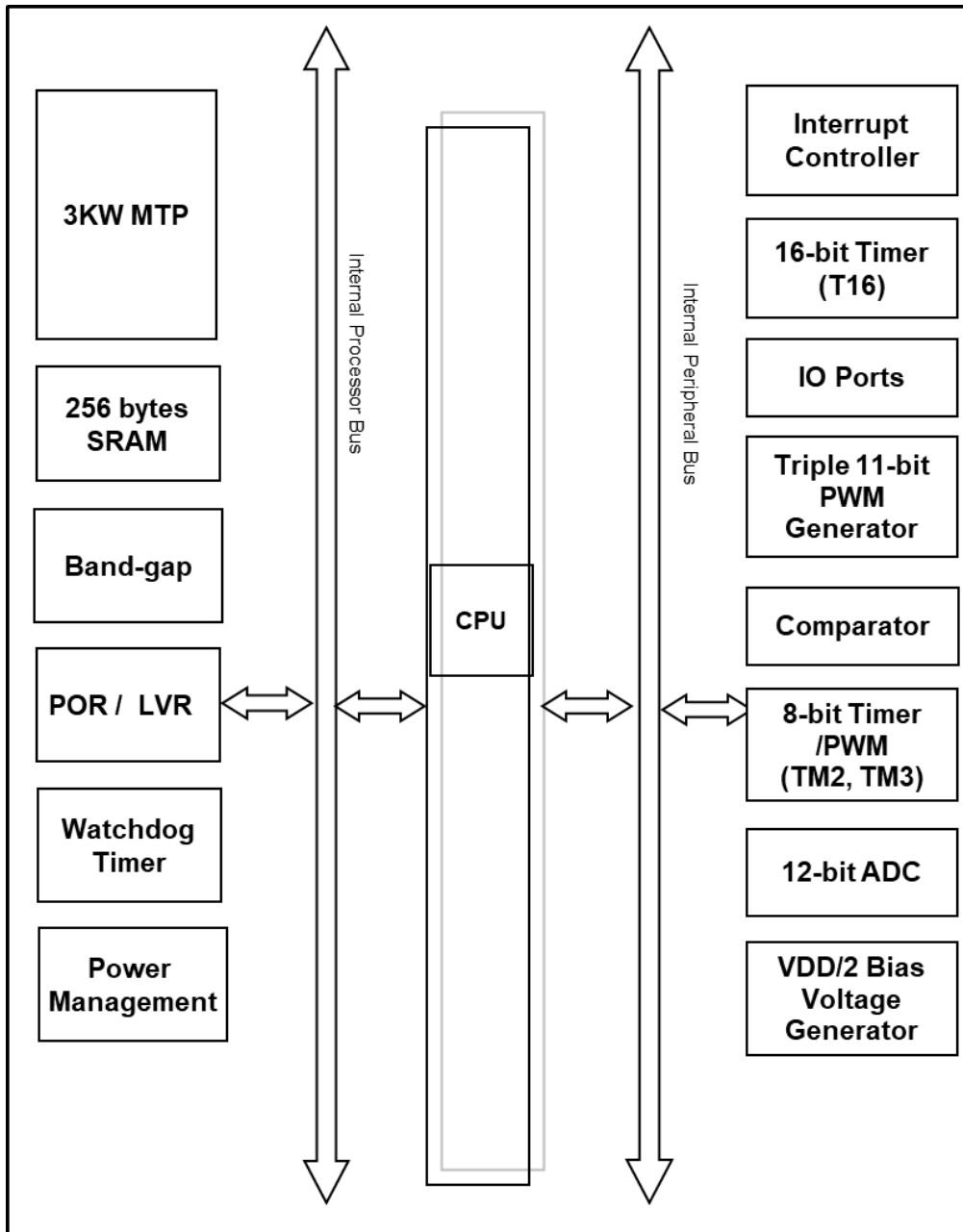

### 3. Pin Assignment and Description

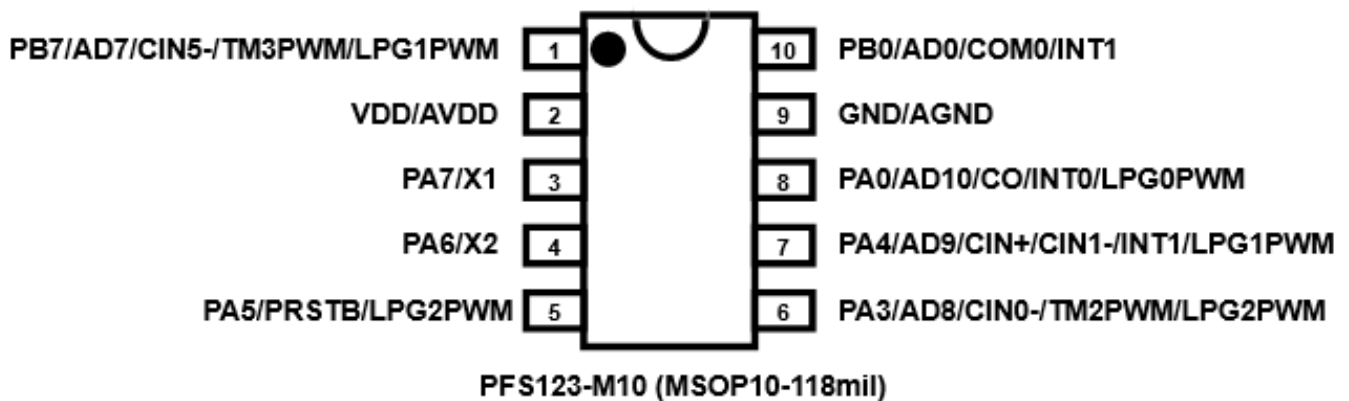
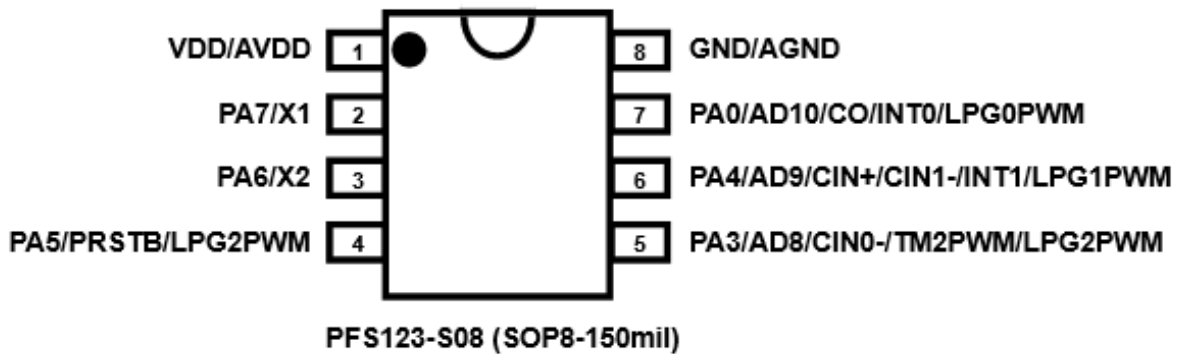
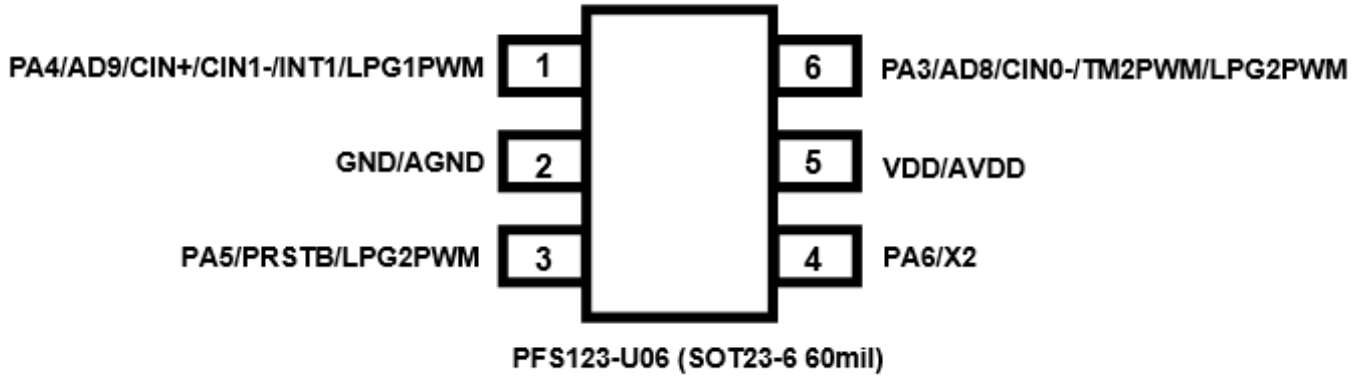

# PFS123

## 8bit MTP MCU with 12-bit R-Type ADC

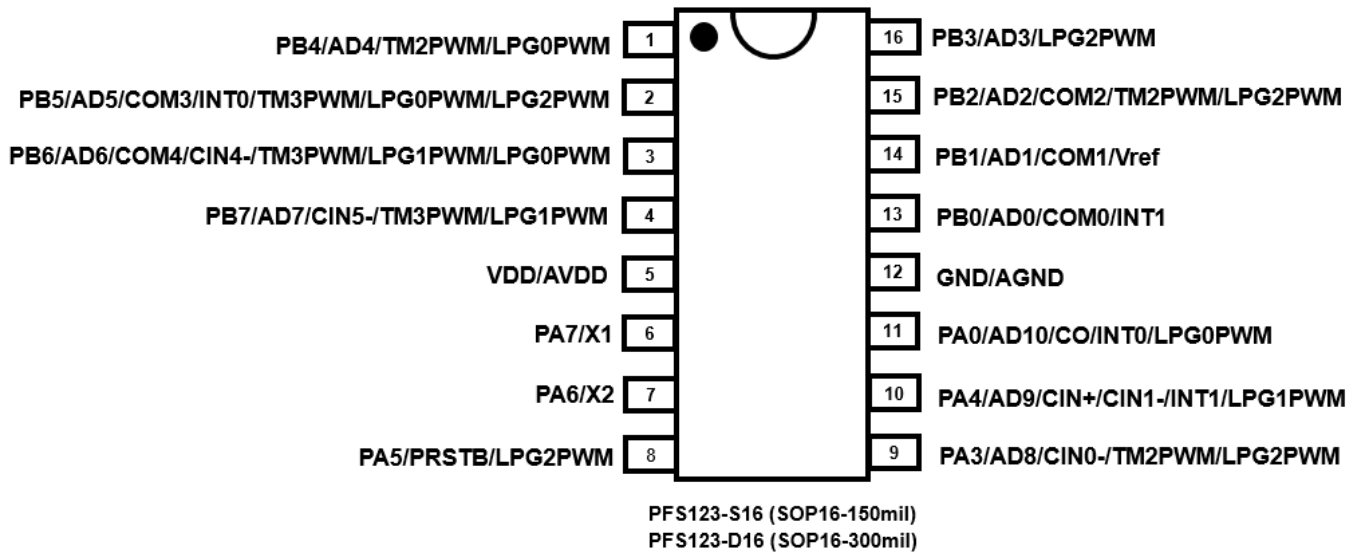
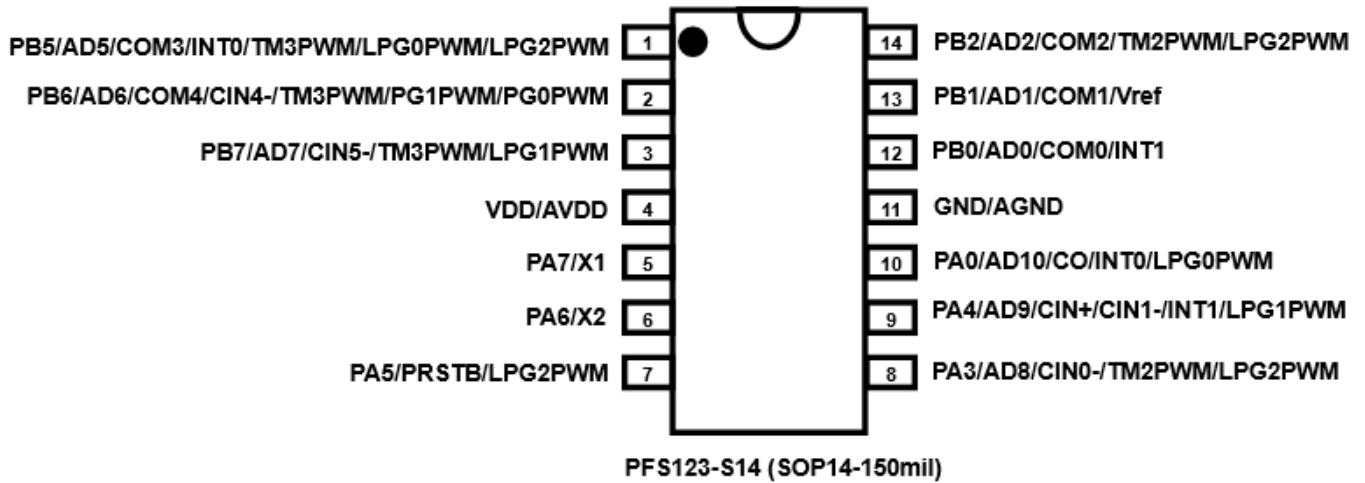

# PFS123

## 8bit MTP MCU with 12-bit R-Type ADC

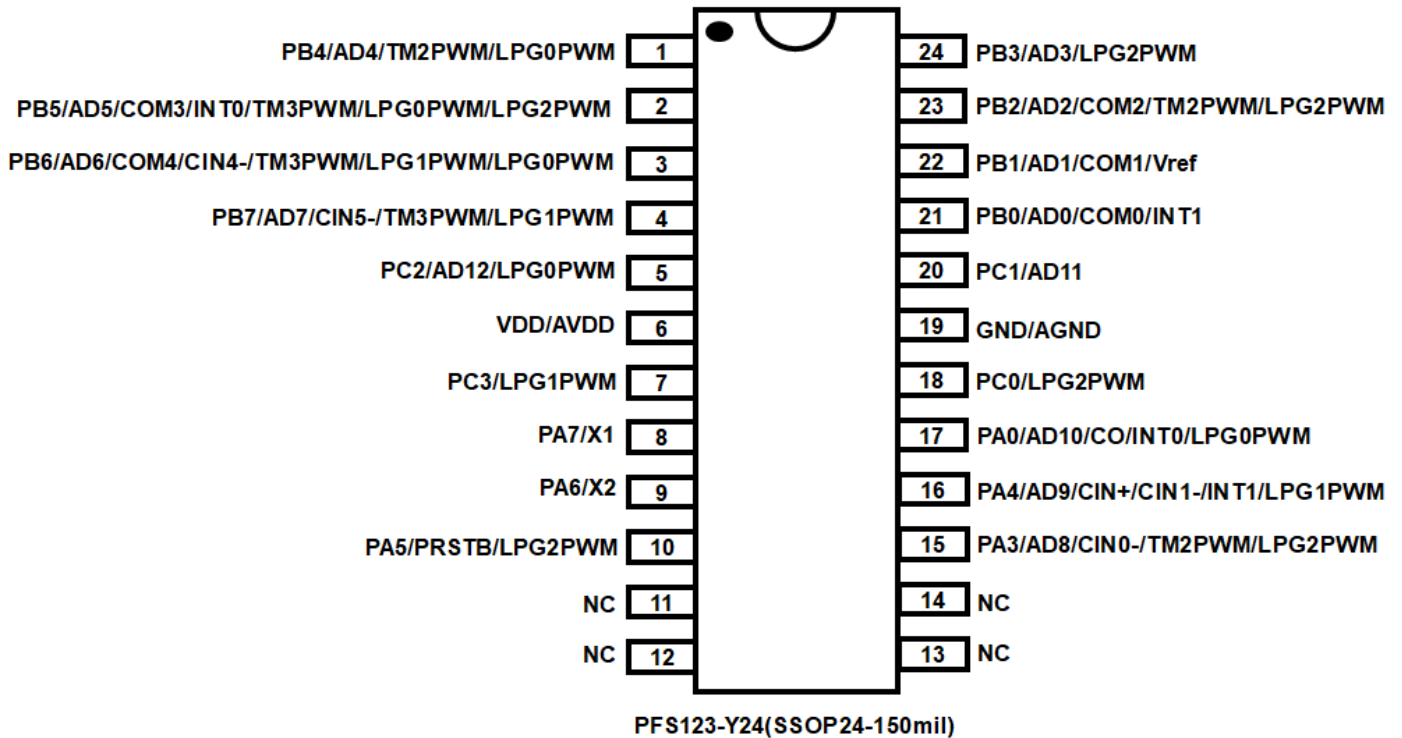
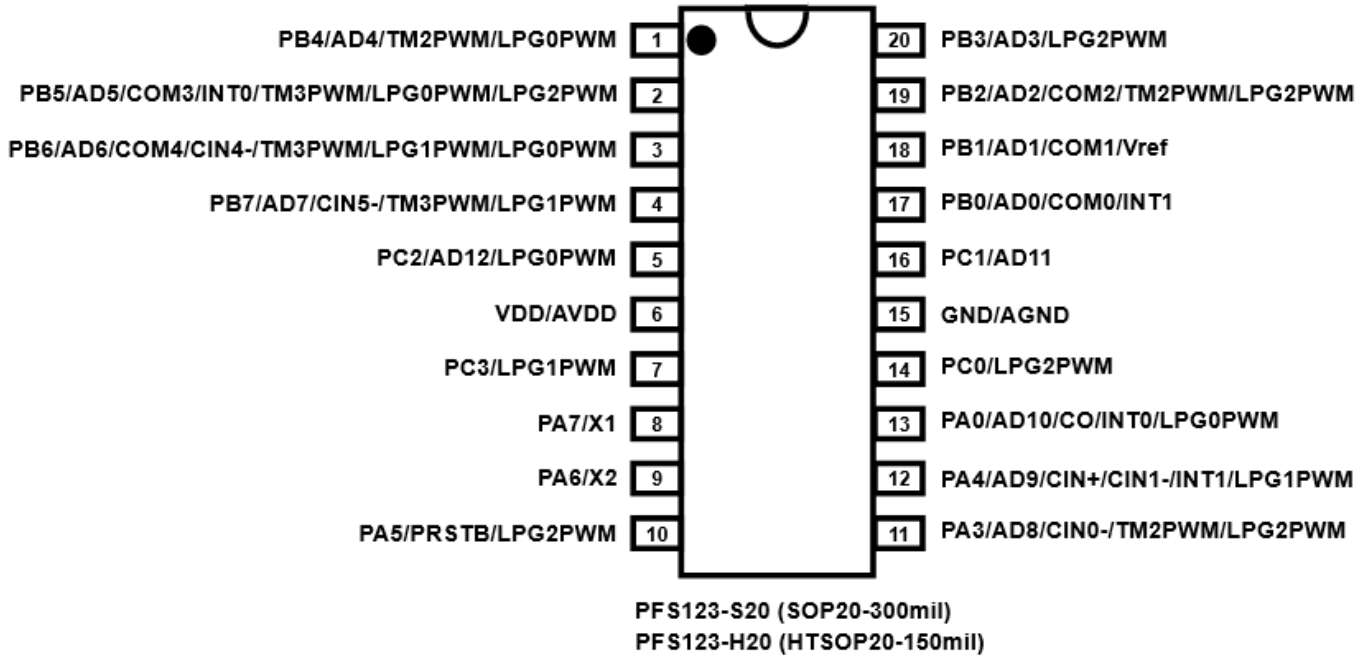

# PFS123

## 8bit MTP MCU with 12-bit R-Type ADC

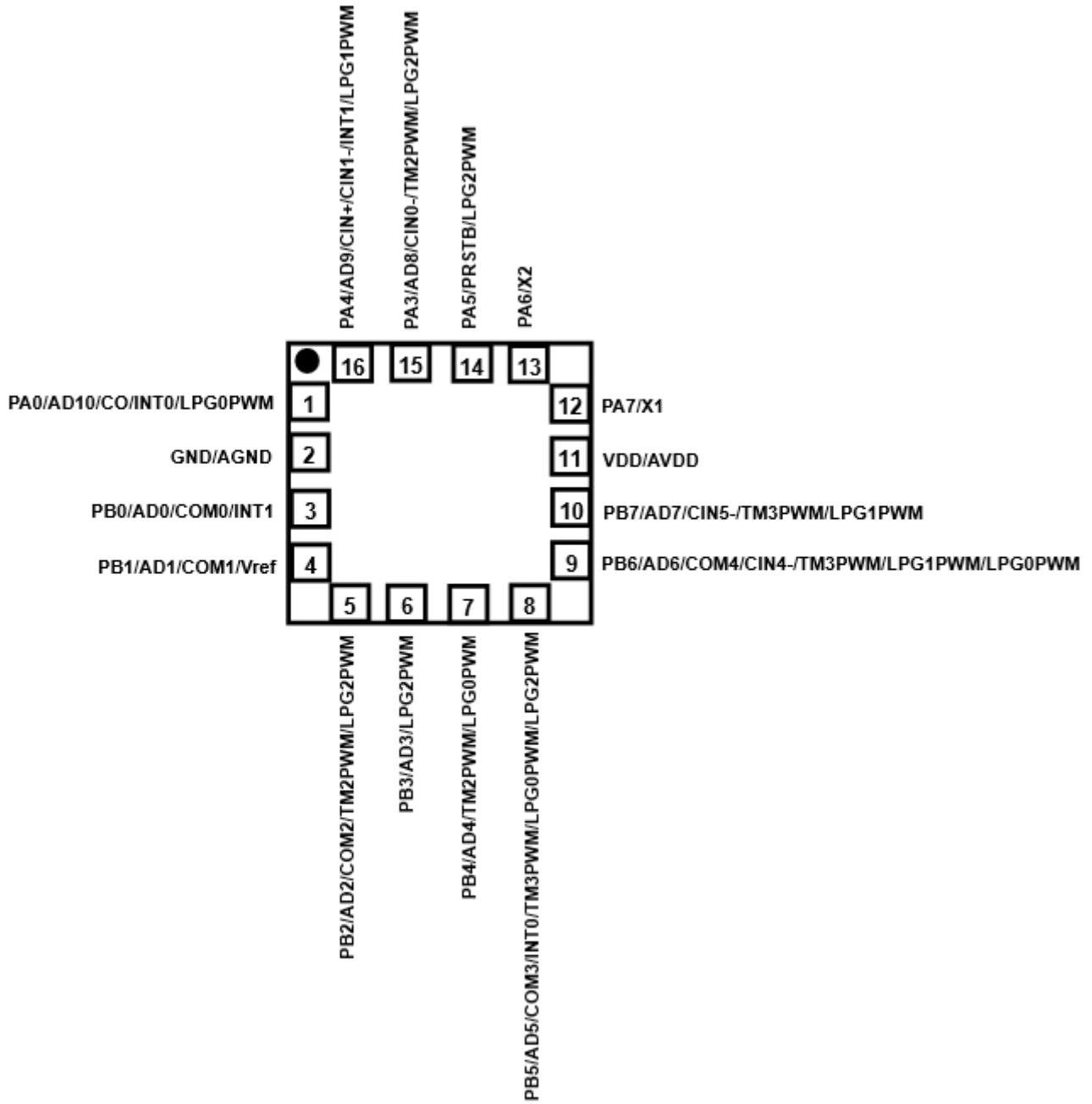

PFS123-1J216A (QFN3\*3-16P-0.5pitch)

# PFS123

## 8bit MTP MCU with 12-bit R-Type ADC

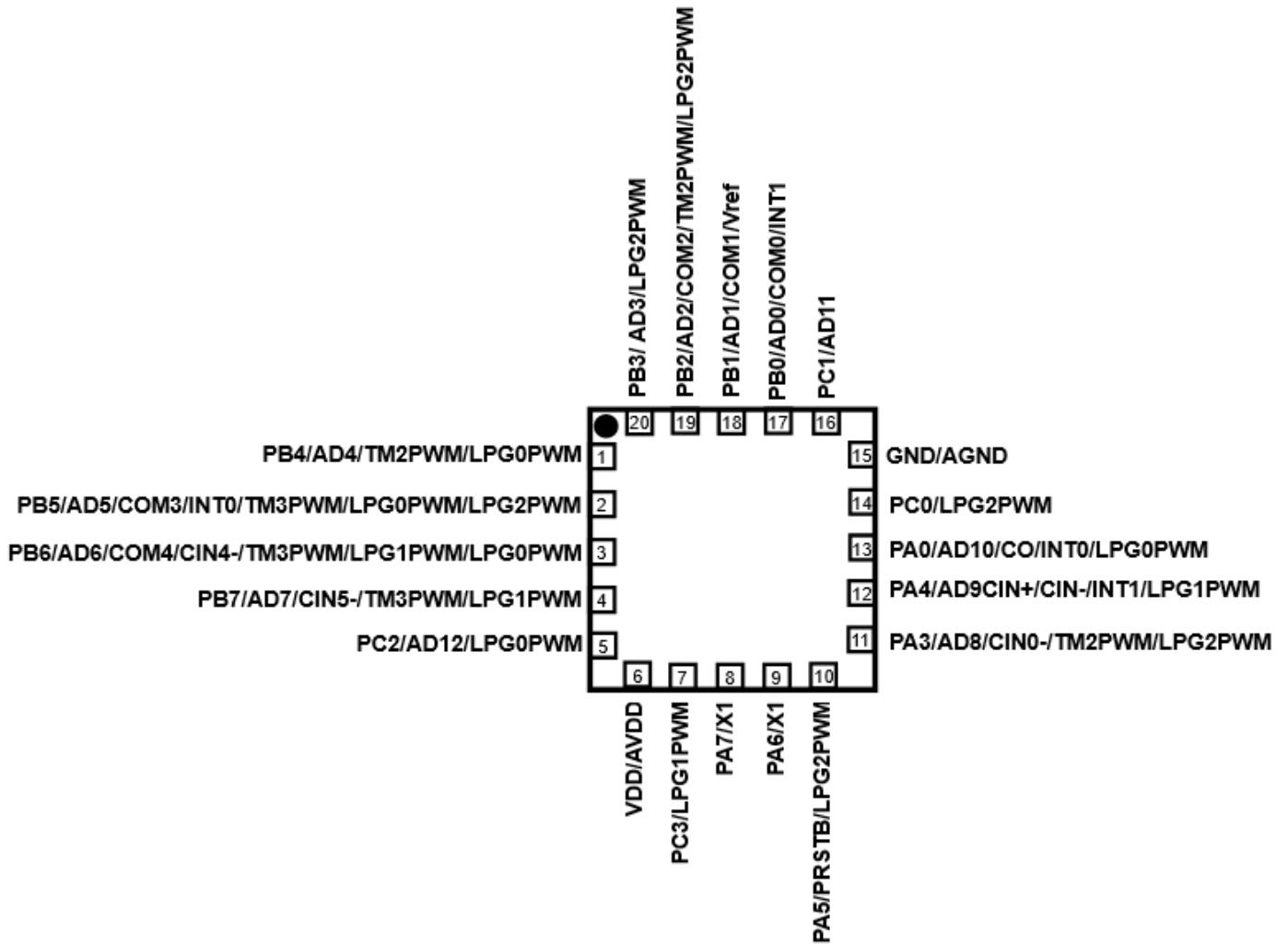

PFS123-1J20A(QFN3\*3-20P)

Pin Name	Pin Type & Buffer Type	Description
PA7 / X1	IO ST / CMOS	<p>The functions of this pin can be:</p> <p>(1) Bit 7 of port A. It can be configured as digital input or two-state output, with pull-high resistor.</p> <p>(2) X1 is Crystal XIN(X1) when crystal oscillator is used.</p> <p>If this pin is used for crystal oscillator, bit 7 of <b>padier</b> register must be programmed “0” to avoid leakage current. This pin can be used to wake-up system during sleep mode; however, wake-up function is also disabled if bit 7 of <b>padier</b> register is “0”.</p>
PA6 / X2	IO ST / CMOS	<p>The functions of this pin can be:</p> <p>(1) Bit 6 of port A. It can be configured as digital input or two-state output, with pull-high resistor.</p> <p>(2) X2 is Crystal XOUT(X2) when crystal oscillator is used.</p> <p>If this pin is used for crystal oscillator, bit 6 of <b>padier</b> register must be programmed “0” to avoid leakage current. This pin can be used to wake-up system during sleep mode; however, wake-up function is also disabled if bit 6 of <b>padier</b> register is “0”.</p>
PA5 / PRSTB / LPG2PWM	IO (OD) ST / CMOS	<p>The functions of this pin can be:</p> <p>(1) Bit 5 of port A. It can be configured as digital input or open-drain output, with pull-high resistor.</p> <p>(2) Hardware reset.</p> <p>(3) Output of 11-bit PWM generator LPWGM2</p> <p>This pin can be used to wake-up system during sleep mode; however, wake-up function is also disabled if bit 5 of <b>padier</b> register is “0”. <u>Please put 33Ω resistor in series to have high noise immunity when this pin is in input mode.</u></p>
PA4 / AD9 / CIN+ / CIN1- / INT1 / LPG1PWM	IO ST / CMOS / Analog	<p>The functions of this pin can be:</p> <p>(1) Bit 4 of port A. It can be configured as digital input or two-state output, with pull-high resistor.</p> <p>(2) Channel 9 of ADC analog input.</p> <p>(3) Plus, input source of comparator</p> <p>(4) Minus input source 1 of comparator</p> <p>(5) External interrupt line 1. It can be used as an external interrupt line 1. <u>Both rising edge and falling edge are accepted to request interrupt service and configurable by register setting.</u></p> <p>(6) Output of 11-bit PWM generator LPWGM1</p> <p>When this pin is configured as analog input, please use bit 4 of register <b>padier</b> to disable the digital input to prevent current leakage. The bit 4 of <b>padier</b> register can be set to “0” to disable digital input; wake-up from power-down by toggling this pin is also disabled.</p>



Pin Name	Pin Type & Buffer Type	Description
PA3 / AD8 / CIN0- / TM2PWM / LPG2PWM	IO ST / CMOS / Analog	<p>The functions of this pin can be:</p> <ol style="list-style-type: none"> <li>(1) Bit 3 of port A. It can be configured as digital input or two-state output, with pull-high resistor.</li> <li>(2) Channel 8 of ADC analog input</li> <li>(3) Minus input source 0 of comparator</li> <li>(4) PWM output from Timer2</li> <li>(5) Output of 11-bit PWM generator LPWGM2</li> </ol> <p>When this pin is configured as analog input, please use bit 3 of register <i>padier</i> to disable the digital input to prevent current leakage. The bit 3 of <i>padier</i> register can be set to "0" to disable digital input; wake-up from power-down by toggling this pin is also disabled.</p>
PA0 / AD10 / CO / INT0 / LPG0PWM	IO ST / CMOS / Analog	<p>The functions of this pin can be:</p> <ol style="list-style-type: none"> <li>(1) Bit 0 of port A. It can be configured as digital input or two-state output, with pull-high resistor.</li> <li>(2) Channel 10 of ADC analog input</li> <li>(3) Output of comparator</li> <li>(4) External interrupt line 0. It can be used as an external interrupt line 0. <u>Both rising edge and falling edge are accepted to request interrupt service and configurable by register setting.</u></li> <li>(5) Output of 11-bit PWM generator LPWGM0</li> </ol> <p>When this pin is configured as analog input, please use bit 0 of register <i>padier</i> to disable the digital input to prevent current leakage. The bit 0 of <i>padier</i> register can be set to "0" to disable digital input; wake-up from power-down by toggling this pin is also disabled.</p>
PB7 / AD7 / CIN5- / TM3PWM / LPG1PWM	IO ST / CMOS / Analog	<p>The functions of this pin can be:</p> <ol style="list-style-type: none"> <li>(1) Bit 7 of port B. It can be configured as digital input or two-state output, with pull-high resistor independently by software</li> <li>(2) Channel 7 of ADC analog input</li> <li>(3) Minus input source 5 of comparator</li> <li>(4) PWM output from Timer3</li> <li>(5) Output of 11-bit PWM generator LPWGM1</li> </ol> <p>When this pin is configured as analog input, please use bit 7 of register <i>pbdier</i> to disable the digital input to prevent current leakage. The bit 7 of <i>pbdier</i> register can be set to "0" to disable digital input; wake-up from power-down by toggling this pin is also disabled.</p>

Pin Name	Pin Type & Buffer Type	Description
PB6 / AD6 / COM4 / CIN4- / TM3PWM / LPG1PWM / LPG0PWM	IO ST / CMOS / Analog	<p>The functions of this pin can be:</p> <ol style="list-style-type: none"> <li>(1) Bit 6 of port B. It can be configured as digital input or two-state output, with pull-high resistor independently by software.</li> <li>(2) Channel 6 of ADC analog input</li> <li>(3) COM4 to provide (1/2 V<sub>DD</sub>) for LCD display</li> <li>(4) Minus input source 4 of comparator</li> <li>(5) PWM output from Timer3</li> <li>(6) Output of 11-bit PWM generator LPWGM1</li> <li>(7) Output of 11-bit PWM generator LPWGM0</li> </ol> <p>When this pin is configured as analog input, please use bit 6 of register <b><i>pbdier</i></b> to disable the digital input to prevent current leakage. The bit 6 of <b><i>pbdier</i></b> register can be set to “0” to disable digital input; wake-up from power-down by toggling this pin is also disabled.</p>
PB5 / AD5 / COM3 / INT0 / TM3PWM / LPG0PWM / LPG2PWM	IO ST / CMOS / Analog	<p>The functions of this pin can be:</p> <ol style="list-style-type: none"> <li>(1) Bit 5 of port B. It can be configured as digital input or two-state output, with pull-high resistor independently by software.</li> <li>(2) Channel 5 of ADC analog input</li> <li>(3) COM3 to provide (1/2 V<sub>DD</sub>) for LCD display</li> <li>(4) External interrupt line 0. It can be used as an external interrupt line 0. <u>Both rising edge and falling edge are accepted to request interrupt service and configurable by register setting.</u></li> <li>(5) PWM output from Timer3</li> <li>(6) Output of 11-bit PWM generator LPWGM0</li> <li>(7) Output of 11-bit PWM generator LPWGM2</li> </ol> <p>When this pin is configured as analog input, please use bit 5 of register <b><i>pbdier</i></b> to disable the digital input to prevent current leakage. The bit 5 of <b><i>pbdier</i></b> register can be set to “0” to disable digital input; wake-up from power-down by toggling this pin is also disabled.</p>
PB4 / AD4 / TM2PWM / LPG0PWM	IO ST / CMOS / Analog	<p>The functions of this pin can be:</p> <ol style="list-style-type: none"> <li>(1) Bit 4 of port B. It can be configured as digital input or two-state output, with pull-high resistor independently by software.</li> <li>(2) Channel 4 of ADC analog input</li> <li>(3) PWM output from Timer2</li> <li>(4) Output of 11-bit PWM generator LPWGM0</li> </ol> <p>When this pin is configured as analog input, please use bit 4 of register <b><i>pbdier</i></b> to disable the digital input to prevent current leakage. The bit 4 of <b><i>pbdier</i></b> register can be set to “0” to disable digital input; wake-up from power-down by toggling this pin is also disabled.</p>

Pin Name	Pin Type & Buffer Type	Description
PB3 / AD3 / LPG2PWM	IO ST / CMOS / Analog	<p>The functions of this pin can be:</p> <ol style="list-style-type: none"> <li>(1) Bit 3 of port B. It can be configured as digital input or two-state output, with pull-high / pull-low resistor independently by software.</li> <li>(2) Channel 3 of ADC analog input</li> <li>(3) Output of 11-bit PWM generator LPWGM2</li> </ol> <p>When this pin is configured as analog input, please use bit 3 of register <b><i>pbdier</i></b> to disable the digital input to prevent current leakage. The bit 3 of <b><i>pbdier</i></b> register can be set to “0” to disable digital input; wake-up from power-down by toggling this pin is also disabled.</p>
PB2 / AD2 / COM2 / TM2PWM / LPG2PWM	IO ST / CMOS / Analog	<p>The functions of this pin can be:</p> <ol style="list-style-type: none"> <li>(1) Bit 2 of port B. It can be configured as digital input or two-state output, with pull-high / pull-low resistor independently by software.</li> <li>(2) Channel 2 of ADC analog input</li> <li>(3) COM2 to provide (1/2 VDD) for LCD display</li> <li>(4) PWM output from Timer2</li> <li>(5) Output of 11-bit PWM generator LPWGM2</li> </ol> <p>When this pin is configured as analog input, please use <i>pbdier.2</i> to disable the digital input to prevent current leakage. The <i>pbdier.2</i> can be set to “0” to disable digital input; wake-up from power-down by toggling this pin is also disabled.</p>
PB1 / AD1 / COM1 / Vref	IO ST / CMOS / Analog	<p>The functions of this pin can be:</p> <ol style="list-style-type: none"> <li>(1) Bit 1 of port B. It can be configured as digital input or two-state output, with pull-high resistor independently by software.</li> <li>(2) Channel 1 of ADC analog input</li> <li>(3) COM1 to provide (1/2 V<sub>DD</sub>) for LCD display</li> <li>(4) External reference high voltage for ADC</li> </ol> <p>When this pin is configured as analog input, please use bit 1 of register <b><i>pbdier</i></b> to disable the digital input to prevent current leakage. The bit 1 of <b><i>pbdier</i></b> register can be set to “0” to disable digital input; wake-up from power-down by toggling this pin is also disabled.</p>
PB0 / AD0 / COM0 / INT1	IO ST / CMOS / Analog	<p>The functions of this pin can be:</p> <ol style="list-style-type: none"> <li>(1) Bit 0 of port B. It can be configured as digital input or two-state output, with pull-high resistor independently by software.</li> <li>(2) Channel 0 of ADC analog input</li> <li>(3) COM0 to provide (1/2 V<sub>DD</sub>) for LCD display</li> <li>(4) External interrupt line 1. It can be used as an external interrupt line 1. <u>Both rising edge and falling edge are accepted to request interrupt service and configurable by register setting.</u></li> </ol> <p>When this pin is configured as analog input, please use bit 0 of register <b><i>pbdier</i></b> to disable the digital input to prevent current leakage. The bit 0 of <b><i>pbdier</i></b> register can be set to “0” to disable digital input; wake-up from power-down by toggling this pin is also disabled.</p>

Pin Name	Pin Type & Buffer Type	Description
PC3 / LPG1PWM	IO ST / CMOS	<p>The functions of this pin can be:</p> <p>(1) Bit 3 of port B. It can be configured as digital input or two-state output, with pull-high resistor independently by software.</p> <p>(2) Output of 11-bit PWM generator LPWVG1</p> <p>The bit 3 of <i>pcdier</i> register can be set to “0” to disable digital input; wake-up from power-down by toggling this pin is also disabled.</p>
PC2 / AD12 / LPG0PWM	IO ST / CMOS / Analog	<p>The functions of this pin can be:</p> <p>(1) Bit 2 of port C. It can be configured as digital input or two-state output, with pull-high resistor independently by software.</p> <p>(2) Channel 12 of ADC analog input</p> <p>(3) Output of 11-bit PWM generator LPWVG0</p> <p>When this pin is configured as analog input, please use bit 2 of register <i>pcdier</i> to disable the digital input to prevent current leakage. The bit 2 of <i>pcdier</i> register can be set to “0” to disable digital input; wake-up from power-down by toggling this pin is also disabled.</p>
PC1 / AD11	IO ST / CMOS / Analog	<p>The functions of this pin can be:</p> <p>(1) Bit 1 of port C. It can be configured as digital input or two-state output, with pull-high / pull-low resistor independently by software.</p> <p>(2) Channel 11 of ADC analog input</p> <p>When this pin is configured as analog input, please use bit 1 of register <i>pcdier</i> to disable the digital input to prevent current leakage. The bit 1 of <i>pcdier</i> register can be set to “0” to disable digital input; wake-up from power-down by toggling this pin is also disabled.</p>
PC0 / LPG2PWM	IO ST / CMOS	<p>The functions of this pin can be:</p> <p>(1) Bit 0 of port C. It can be configured as digital input or two-state output, with pull-high / pull-low resistor independently by software.</p> <p>(2) Output of 11-bit PWM generator LPWVG2</p> <p>The bit 0 of <i>pcdier</i> register can be set to “0” to disable digital input; wake-up from power-down by toggling this pin is also disabled.</p>
VDD/ AVDD	VDD/ AVDD	<p>VDD: Digital positive power</p> <p>AVDD: Analog positive power</p> <p>VDD is the IC power supply while AVDD is the ADC power supply. AVDD and VDD are double bonding internally and they have the same external pin.</p>
GND / AGND	GND / AGND	<p>GND: Digital negative power</p> <p>AGND: Analog negative power</p> <p>GND is the IC ground pin while AGND is the ADC ground pin. AGND and GND are double bonding internally and they have the same external pin.</p>
<p>Notes: <b>IO</b>: Input/Output; <b>ST</b>: Schmitt Trigger input; <b>OD</b>: Open Drain; <b>Analog</b>: Analog input pin  <b>CMOS</b>: CMOS voltage level</p>		

### 4. Device Characteristics

#### 4.1. AC/DC Device Characteristics

All data are acquired under the conditions of  $T_a = -40^{\circ}\text{C} \sim 85^{\circ}\text{C}$ ,  $V_{DD}=5.0\text{V}$ ,  $f_{SYS} = 2\text{MHz}$  unless noted.

Symbol	Description	Min	Typ	Max	Unit	Conditions ( $T_a=25^{\circ}\text{C}$ )
$V_{DD}$	Operating Voltage	2.2 #	5.0	5.5	V	# Subject to LVR tolerance
LVR%	Low Voltage Reset Tolerance	-5		5	%	
$f_{SYS}$	System clock (CLK)* =					
	IHRC/2	0		8M	Hz	$V_{DD} \geq 3.5\text{V}$
	IHRC/4	0		4M		$V_{DD} \geq 2.5\text{V}$
	IHRC/8	0		2M		$V_{DD} \geq 2.2\text{V}$
ILRC		98K		$V_{DD} = 5.0\text{V}$		
$P_{cycle}$	Program cycle	1000			cycles	
$V_{POR}$	Power On Reset Voltage		2.0*			* Subject to LVR tolerance
$I_{OP}$	Operating Current		0.6		mA	$f_{SYS}=IHRC/16=1\text{MIPS}@5.0\text{V}$
			86		$\mu\text{A}$	$f_{SYS}=ILRC=96\text{KHz}@5.0\text{V}$
$I_{PD}$	Power Down Current (by <b>stopsys</b> command)		0.7		$\mu\text{A}$	$f_{SYS}= 0\text{Hz}, V_{DD}=5.0\text{V}$
			0.4		$\mu\text{A}$	$f_{SYS}= 0\text{Hz}, V_{DD}=3.3\text{V}$
$I_{PS}$	Power Save Current (by <b>stopexe</b> command)		3.5		$\mu\text{A}$	$V_{DD} = 5.0\text{V}; f_{SYS} = \text{ILRC}$ Only ILRC module is enabled.
$V_{IL}$	Input low voltage for IO lines	0		$0.1 V_{DD}$	V	
$V_{IH}$	Input high voltage for IO lines	$0.8 V_{DD}$		$V_{DD}$	V	PA5
		$0.7 V_{DD}$		$V_{DD}$		Other IO
IO lines Sink current						
$I_{OL}$	PB4, PB5 (Normal)		10		mA	$V_{DD}=5.0\text{V}, V_{OL}=0.5\text{V}$
	PB4, PB5 (Strong)		40			
	PC0, PC2, PC3		30			
	Other IOs		10			
IO lines Drive current						
$I_{OH}$	PB4, PB5 (Normal)		10		mA	$V_{DD}=5.0\text{V}, V_{OH}=4.5\text{V}$
	PB4, PB5 (Strong)		20			
	PA5		0			
	Other IOs		10			
$V_{IN}$	Input voltage	-0.3		$V_{DD}+0.3$	V	
$I_{INJ}(\text{PIN})$	Injected current on pin			1	mA	$V_{DD} + 0.3 \geq V_{IN} \geq -0.3$
$R_{PH}$	Pull-high Resistance		67		$\text{K}\Omega$	$V_{DD} = 5.0\text{V}, \text{PB2/PB3/PC0/PC1}$
			92			$V_{DD} = 5.0\text{V}, \text{Other IO}$
$R_{PL}$	Pull-low Resistance		76		$\text{K}\Omega$	$V_{DD} = 5.0\text{V}, \text{PB2/PB3/PC0/PC1}$
$V_{BG}$	Bandgap Reference Voltage	1.145*	1.20*	1.255*	V	$V_{DD} = 2.2\text{V} \sim 5.5\text{V}$ $-40^{\circ}\text{C} < T_a < 85^{\circ}\text{C}^*$

Symbol	Description	Min	Typ	Max	Unit	Conditions (Ta=25°C)
f <sub>IHRC</sub>	Frequency of IHRC after calibration *	15.76*	16*	16.24*	MHz	25°C, V <sub>DD</sub> =2.2V~5.5V
		15.20*	16*	16.80*		V <sub>DD</sub> =2.2V~5.5V, -40°C <Ta<85°C*
t <sub>INT</sub>	Interrupt pulse width	30			ns	V <sub>DD</sub> = 5.0V
V <sub>ADC</sub>	ADC working voltage	2.2		V <sub>DD</sub>	V	
V <sub>AD</sub>	AD Input Voltage	0		V <sub>DD</sub>	V	
ADrs	ADC resolution		12 10		bit	0°C <Ta<50°C* -40°C <Ta<85°C*
ADcs	ADC current consumption		0.9 0.8		mA	@5V @3V
ADclk	ADC clock period		2		us	2.2V ~ 5.5V
t <sub>ADCONV</sub>	ADC conversion time (t <sub>ADCLK</sub> is the period of the selected AD conversion clock)		16		t <sub>ADCLK</sub>	12-bit resolution
AD DNL	ADC Differential Non-Linearity		±4*		LSB	12-bit resolution LSB
AD INL	ADC Integral Non-Linearity		±8*		LSB	12-bit resolution LSB
ADos	ADC offset		5*		mV	@ V <sub>DD</sub> =3V
V <sub>DR</sub>	RAM data retention voltage*	1.5			V	in stop mode
t <sub>WDT</sub>	Watchdog timeout period		8k		T <sub>ILRC</sub>	misc[1:0]=00 (default)
			16k			misc[1:0]=01
			64k			misc[1:0]=10
			256k			misc[1:0]=11
t <sub>WUP</sub>	Wake-up time period (fast)		45		T <sub>ILRC</sub>	Where T <sub>ILRC</sub> is the time period of ILRC
	Wake-up time period (slow)		3000			
t <sub>SBP</sub>	System boot-up period from power-on for slow boot-up		30		ms	V <sub>DD</sub> =5V
	System boot-up period from power-on for Fast boot-up		550		us	V <sub>DD</sub> =5V
t <sub>RST</sub>	External reset pulse width	120			us	@ V <sub>DD</sub> =5V
CPos	Comparator offset*	-	±10	±20	mV	
CPcm	Comparator input common mode*	0		V <sub>DD</sub> -1.5	V	
CPspt	Comparator response time*		100	500	ns	Both Rising and Falling
CPmc	Stable time to change comparator mode		2.5	7.5	us	
CPcs	Comparator current consumption		20		uA	V <sub>DD</sub> = 3.3V

\*These parameters are for design reference, not tested for each chip.

### 4.2. Absolute Maximum Ratings

- Supply Voltage ..... 2.2V ~ 5.5V  
\*If  $V_{DD}$  is over the maximum rating, it may lead to a permanent damage of IC.
- Input Voltage .....  $-0.3V \sim V_{DD} + 0.3V$
- Operating Temperature .....  $-40^{\circ}C \sim 85^{\circ}C$
- Junction Temperature .....  $150^{\circ}C$
- Storage Temperature .....  $-50^{\circ}C \sim 125^{\circ}C$

### 4.3. Typical ILRC frequency vs. VDD

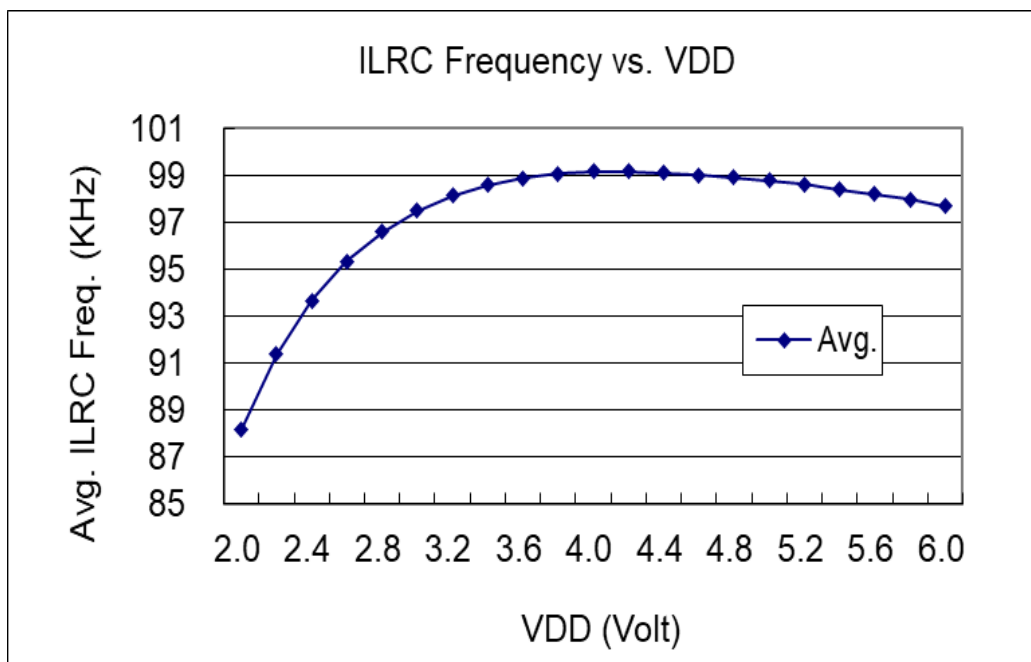

### 4.4. Typical IHRC frequency deviation vs. VDD (calibrated to 16MHz)

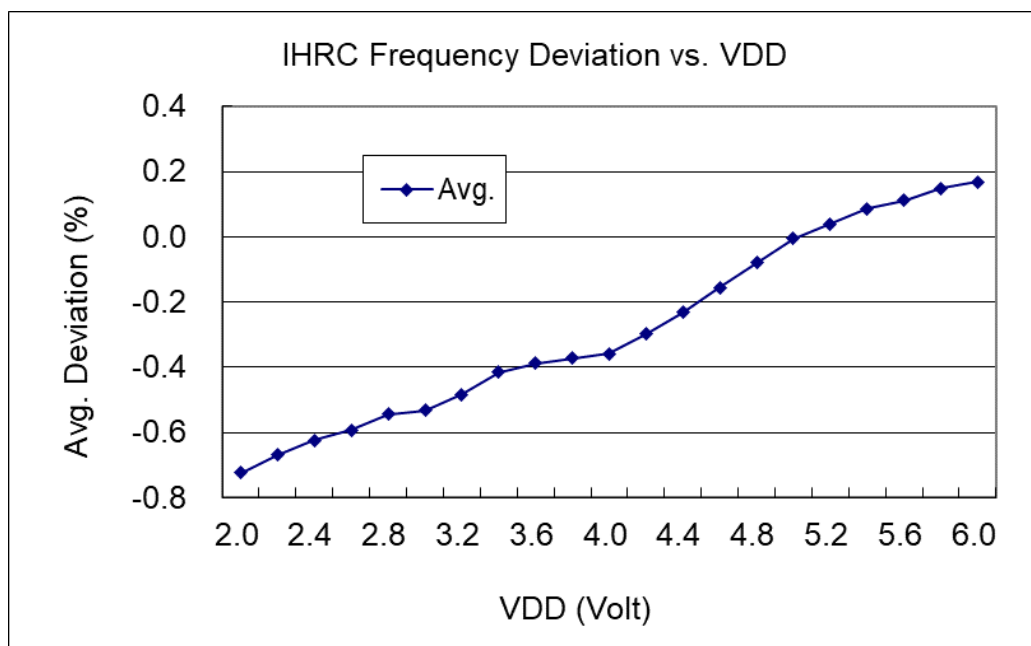

### 4.5. Typical ILRC Frequency vs. Temperature

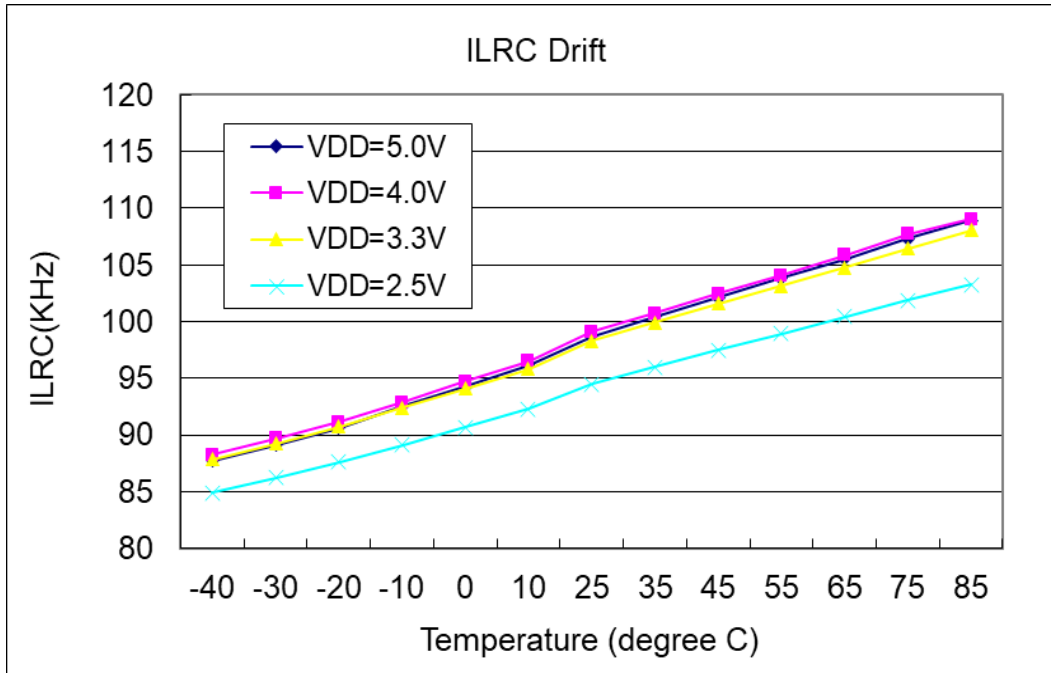

### 4.6. Typical IHRC Frequency vs. Temperature (calibrated to 16MHz)

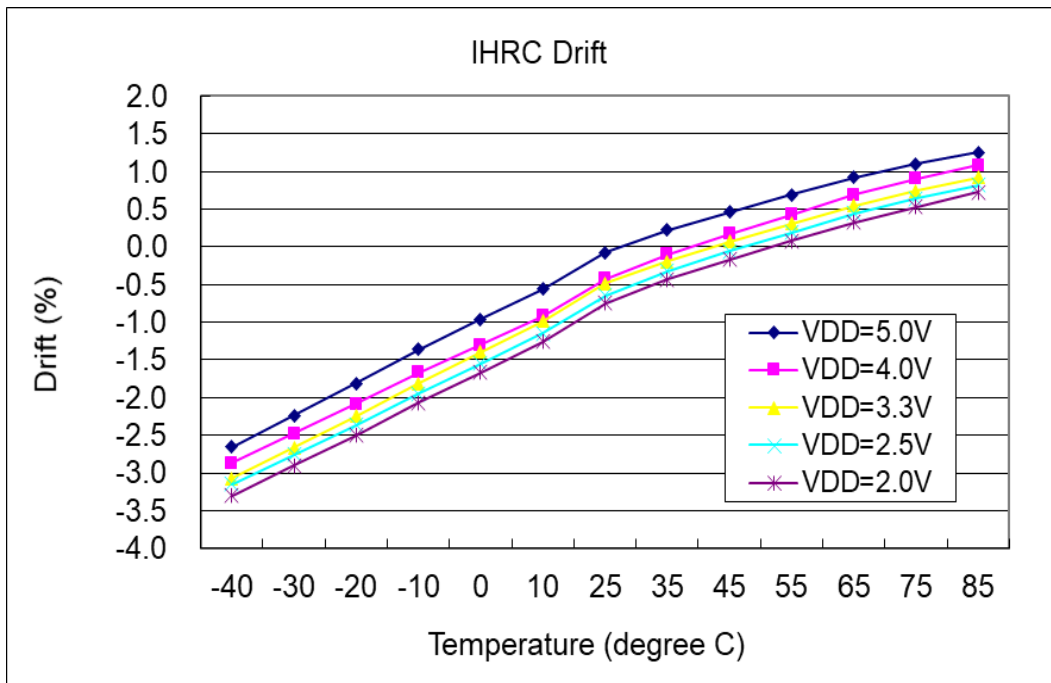



### 4.7. Typical operating current vs. VDD @ system clock = ILRC/n

Conditions: **ON:** ILRC, Bandgap, LVR; **OFF:** IHRC, EOSC, T16, TM2, TM3, ADC modules;  
**IO:** PA0:0.5Hz output toggle and no loading, **others:** input and no floating

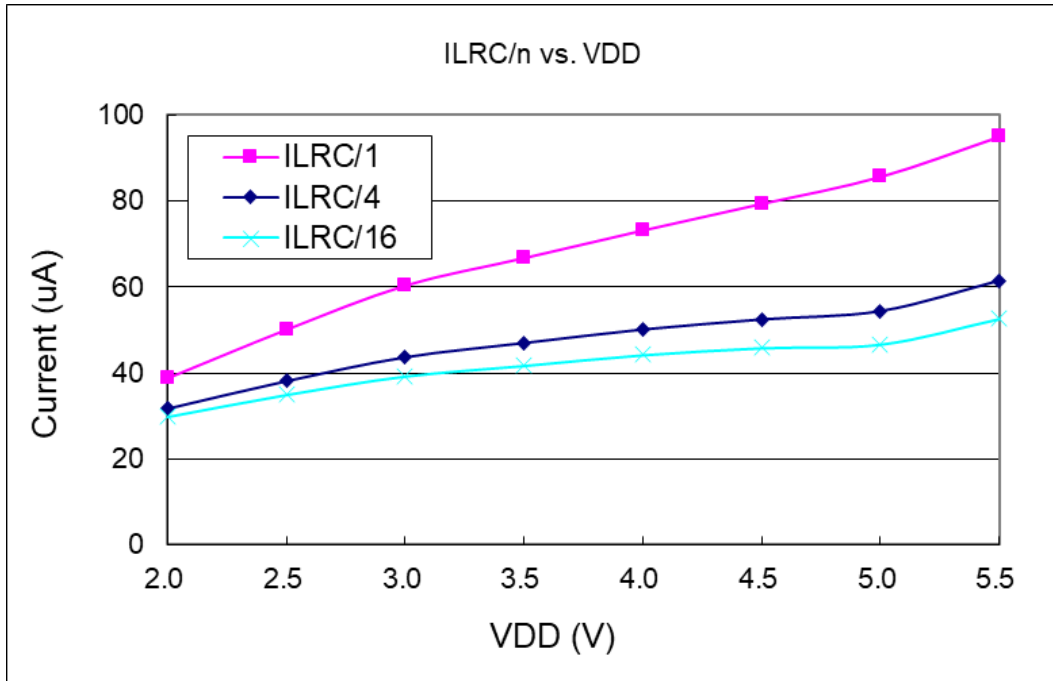

### 4.8. Typical operating current vs. VDD @ system clock = IHRC/n

Conditions: **ON:** IHRC, Bandgap, LVR; **OFF:** ILRC, EOSC, T16, TM2, TM3, ADC modules;  
**IO:** PA0:0.5Hz output toggle and no loading, **others:** input and no floating

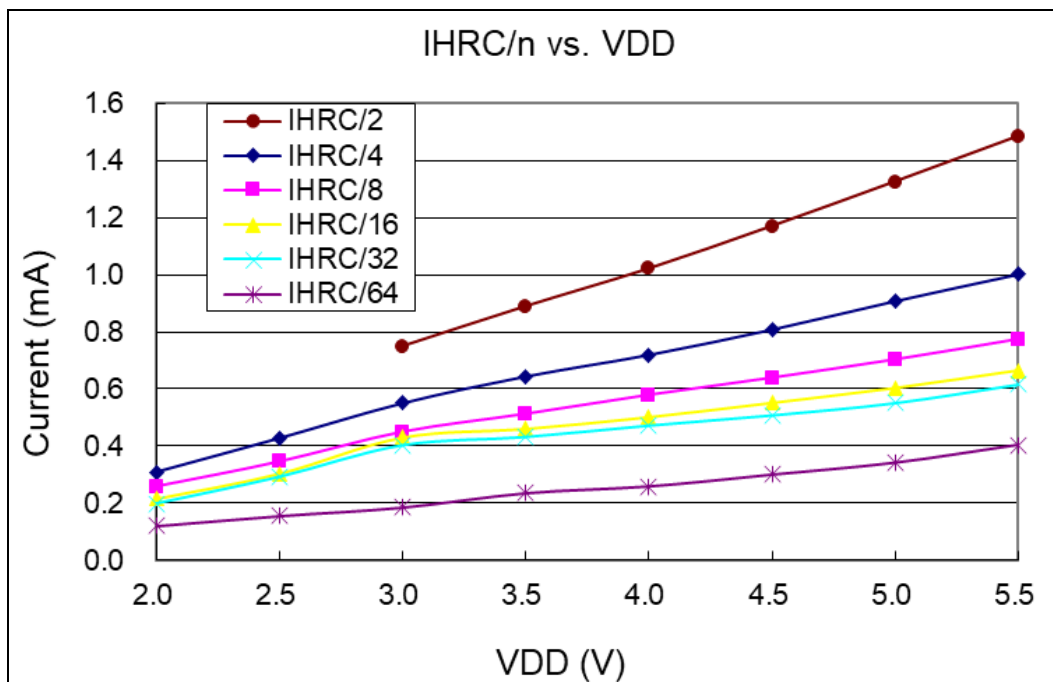

### 4.9. Typical operating current vs. VDD @ system clock = 4MHz EOSC / n

Conditions: **ON:** EOSC[6,5] = [1,1], Bandgap, LVR; **OFF:** IHRC, ILRC, T16, TM2, TM3, ADC modules;  
**IO:** PA0:0.5Hz output toggle and no loading, **others:** input and no floating

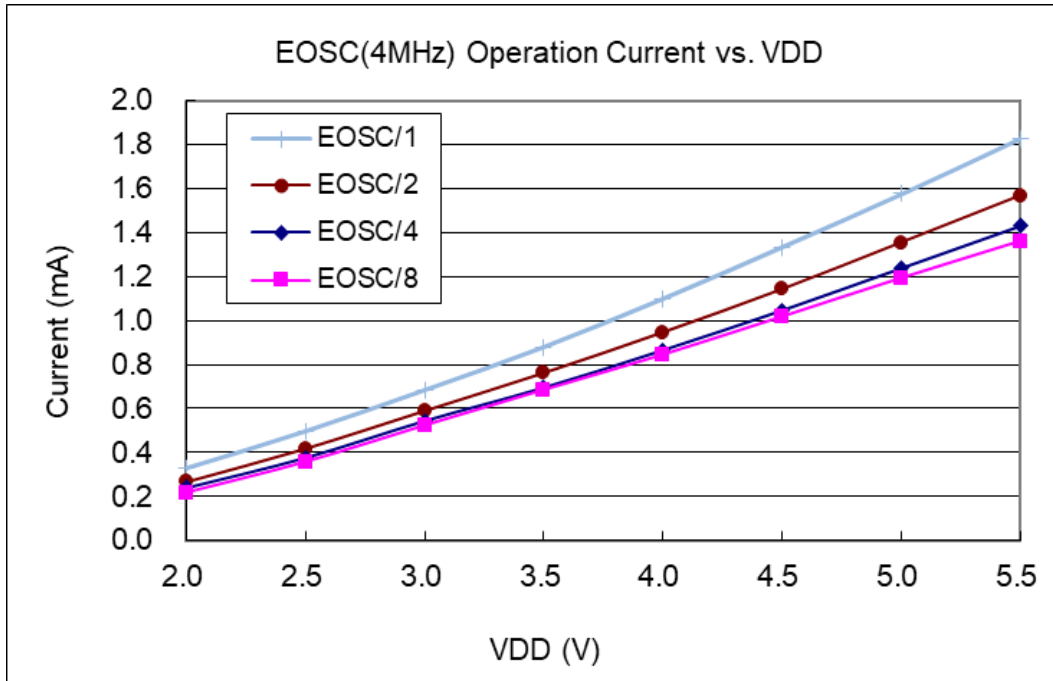

### 4.10. Typical operating current vs. VDD @ system clock = 32KHz EOSC / n

Conditions: **ON:** EOSC[6,5] = [0,1], Bandgap, LVR; **OFF:** IHRC, ILRC, T16, TM2, TM3, ADC modules;  
**IO:** PA0:0.5Hz output toggle and no loading, **others:** input and no floating

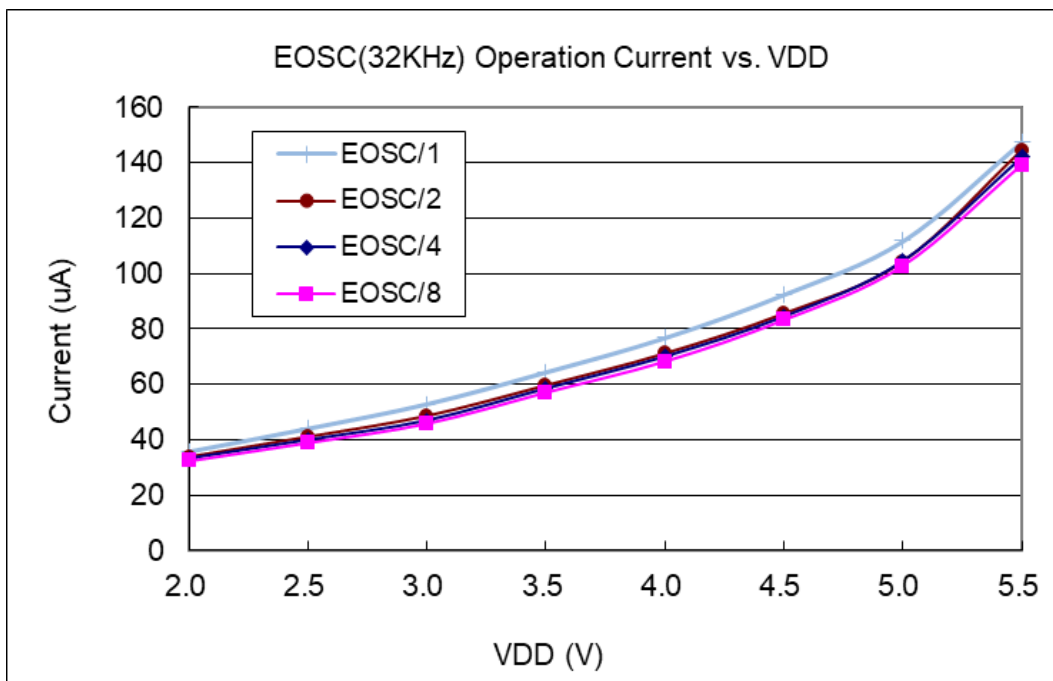

### 4.11. Typical operating current vs. VDD @ system clock = 1MHz EOSC / n

Conditions: **ON:** EOSC[6,5] = [1,0], Bandgap, LVR; **OFF:** IHRC, ILRC, T16, TM2, TM3, ADC modules;  
**IO:** PA0:0.5Hz output toggle and no loading, **others:** input and no floating

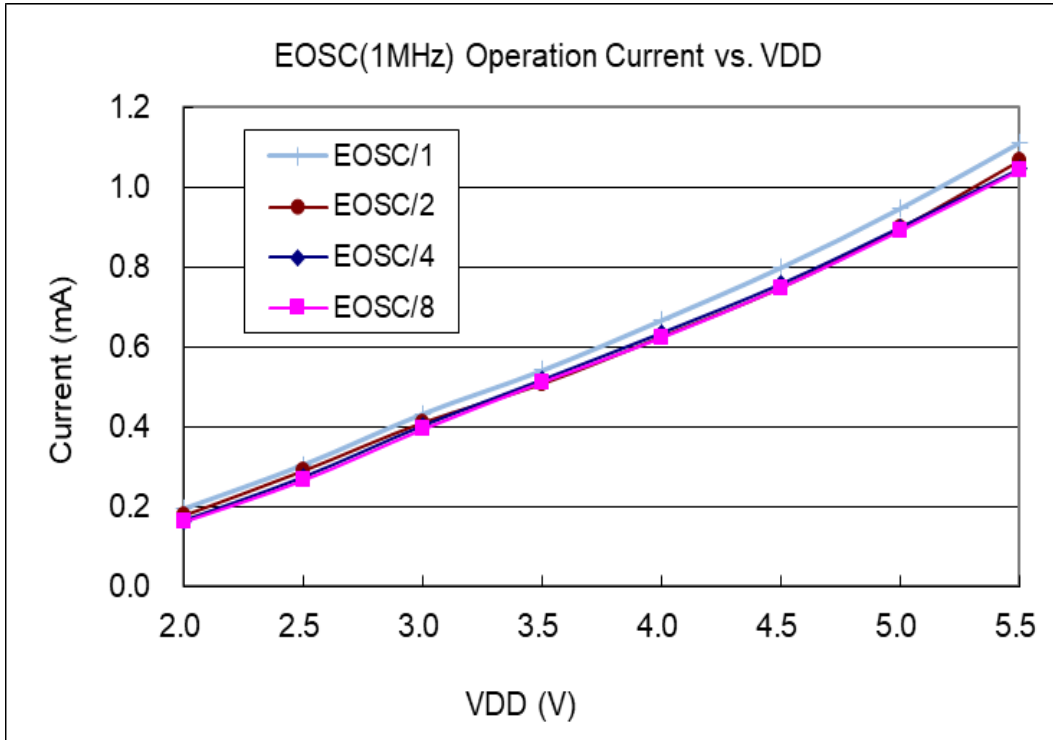

### 4.12. Typical IO driving current (I<sub>OH</sub>) and sink current (I<sub>OL</sub>)

(V<sub>OH</sub>=0.9\*VDD, V<sub>OL</sub>=0.1\*VDD)

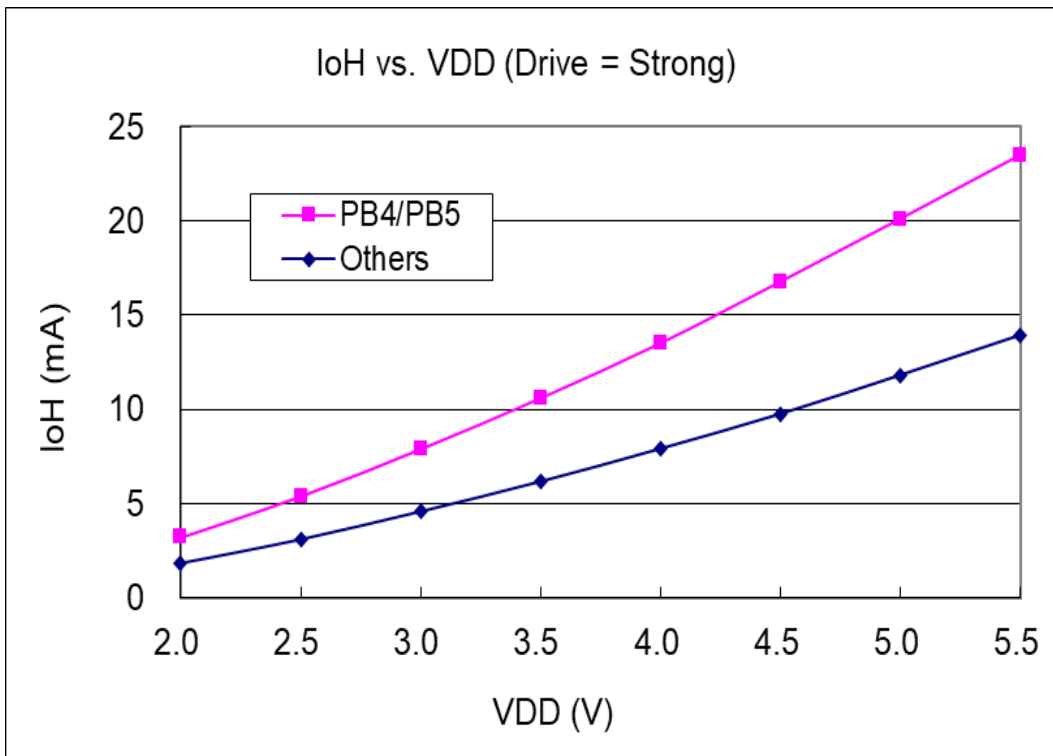

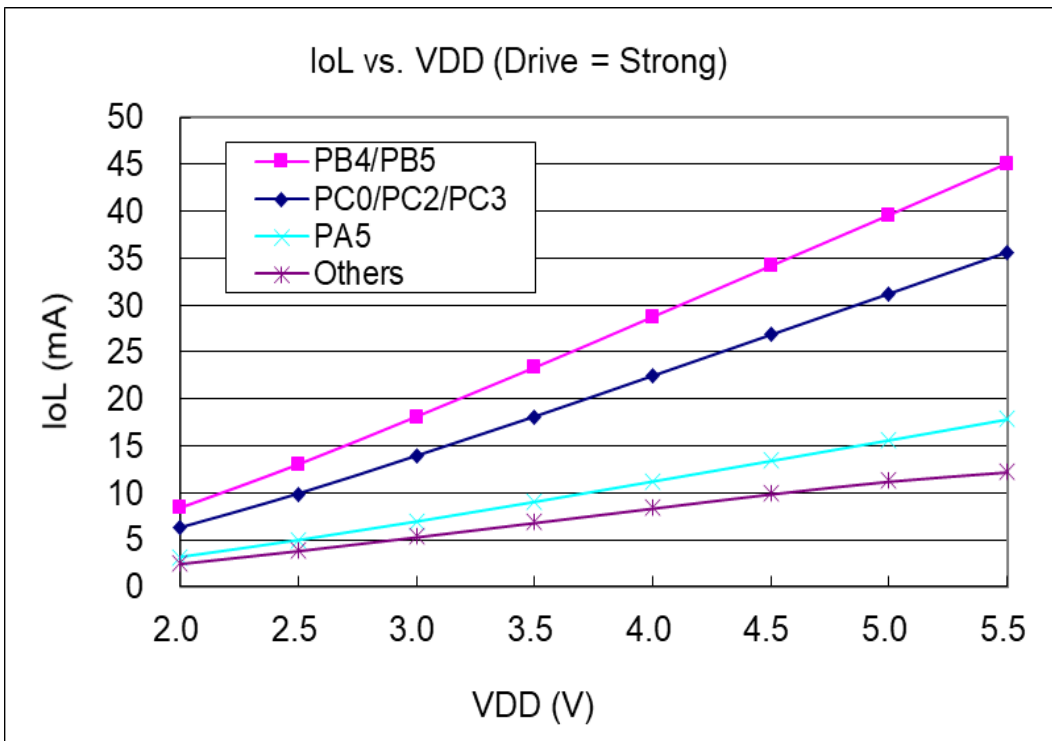
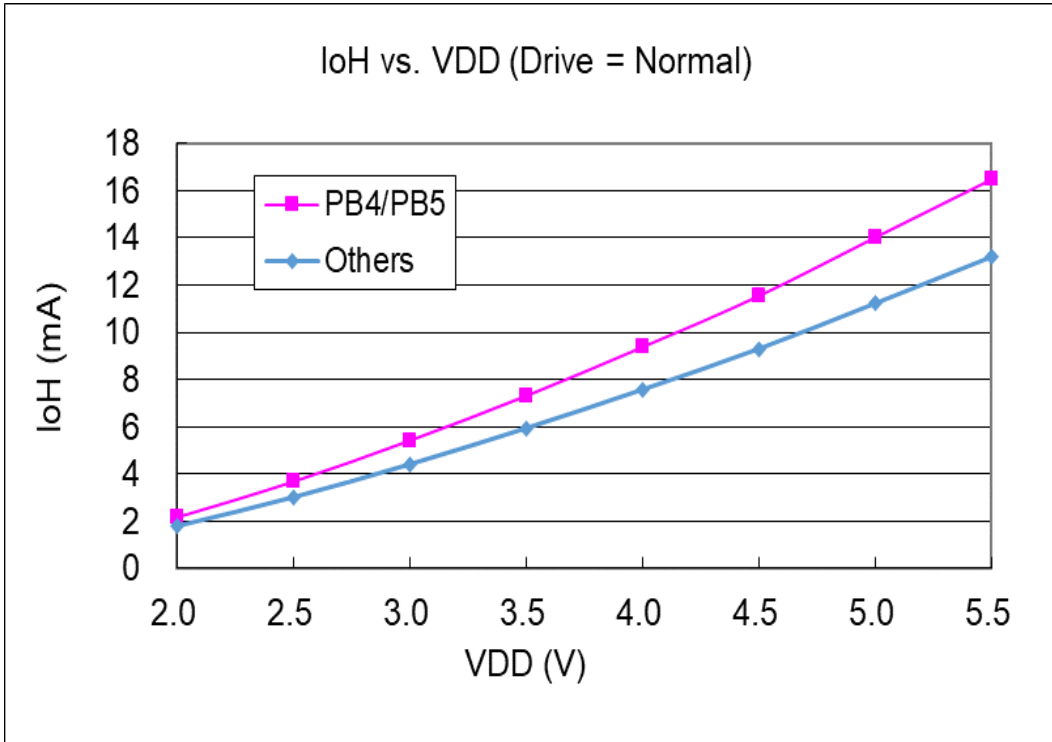

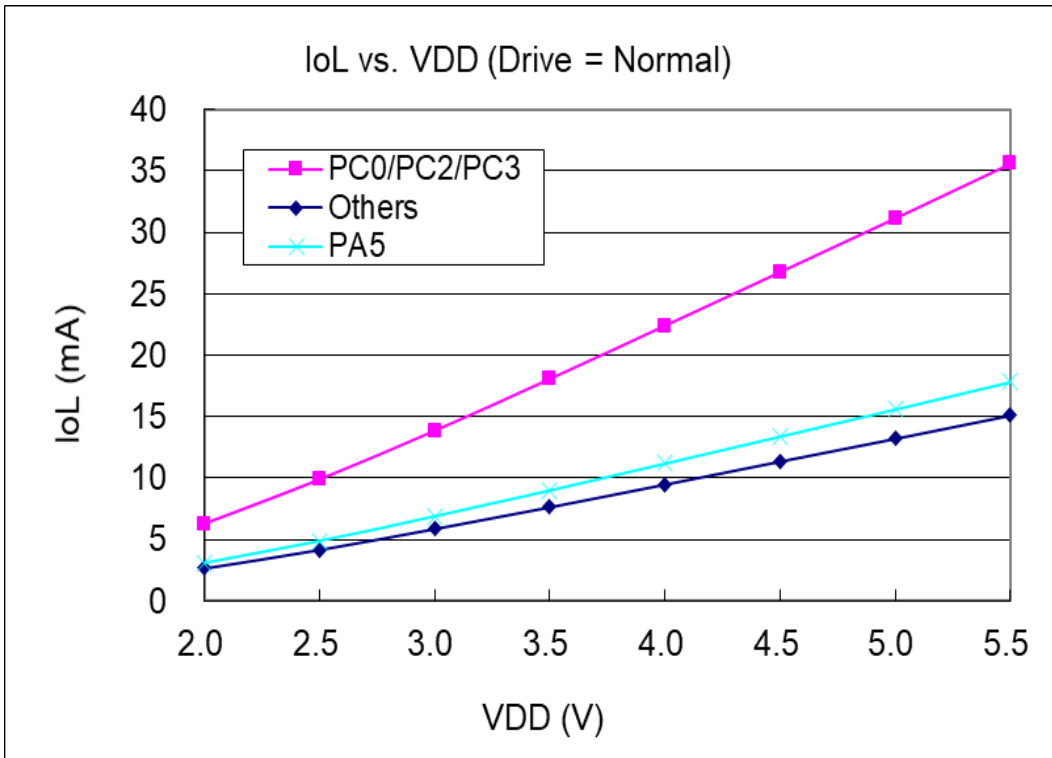

#### 4.13. Typical IO input high/low threshold voltage ( $V_{IH}/V_{IL}$ )

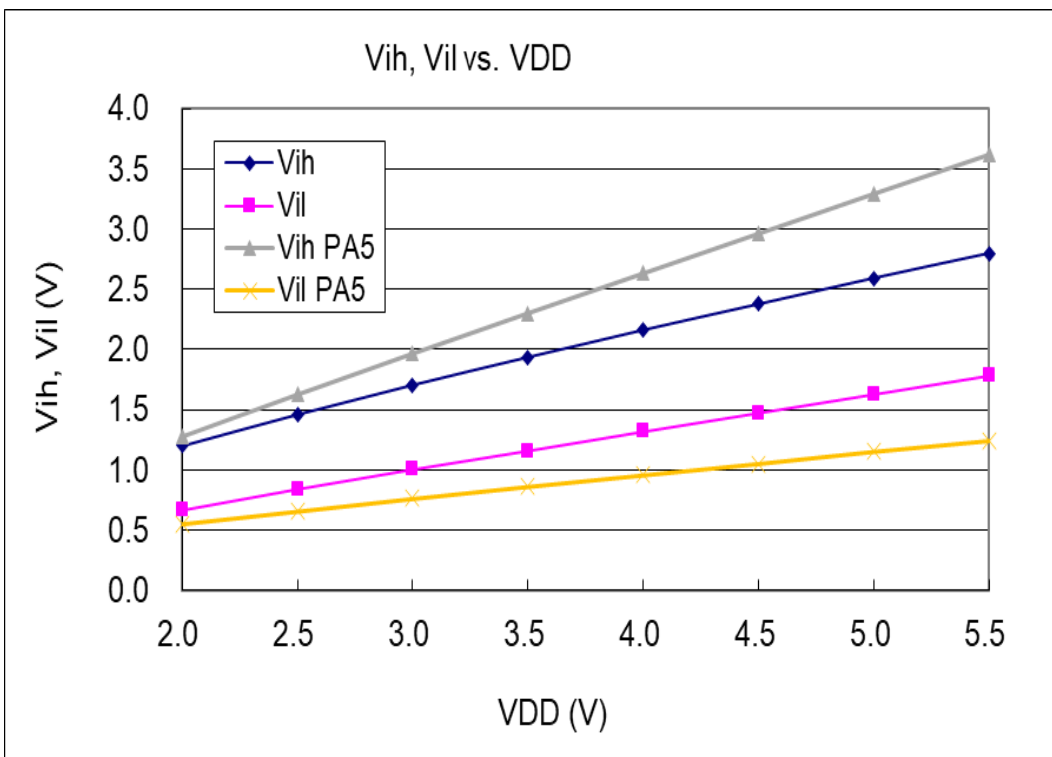

### 4.14. Typical resistance of IO pull high/low device

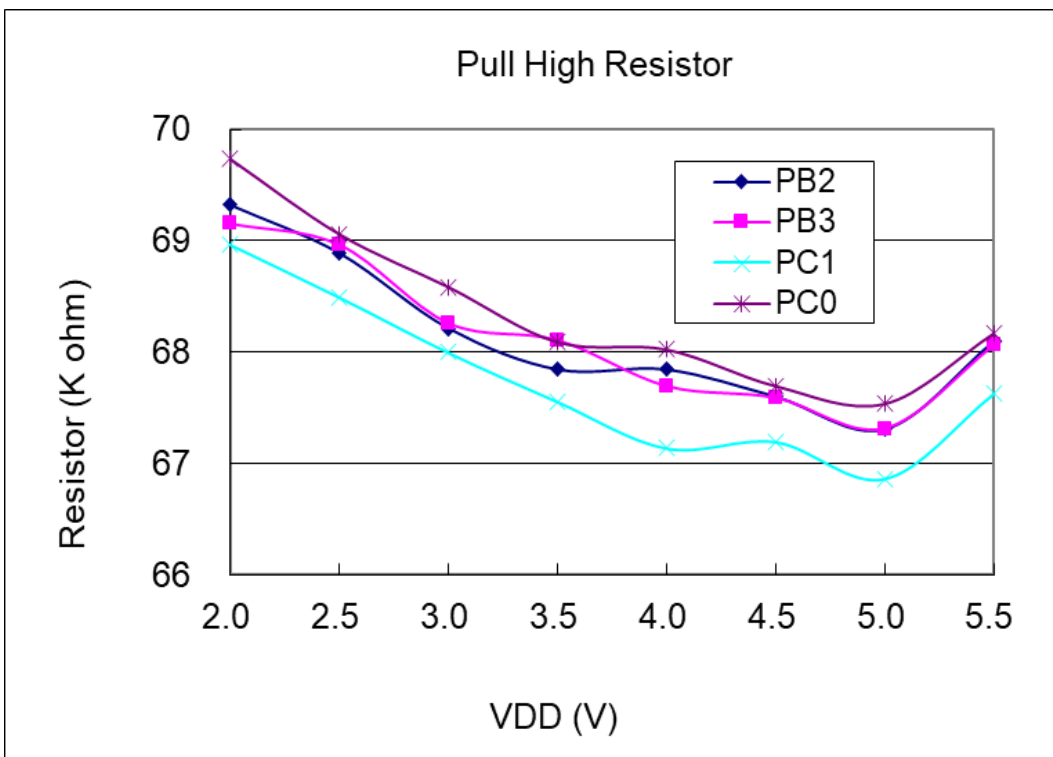
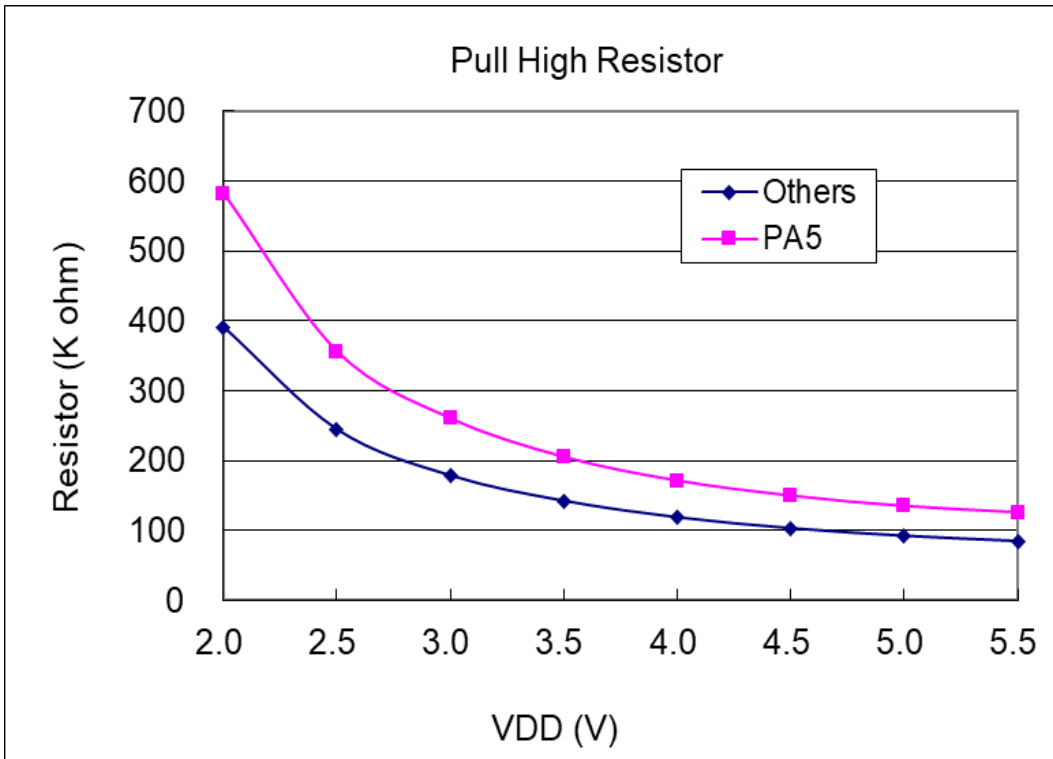

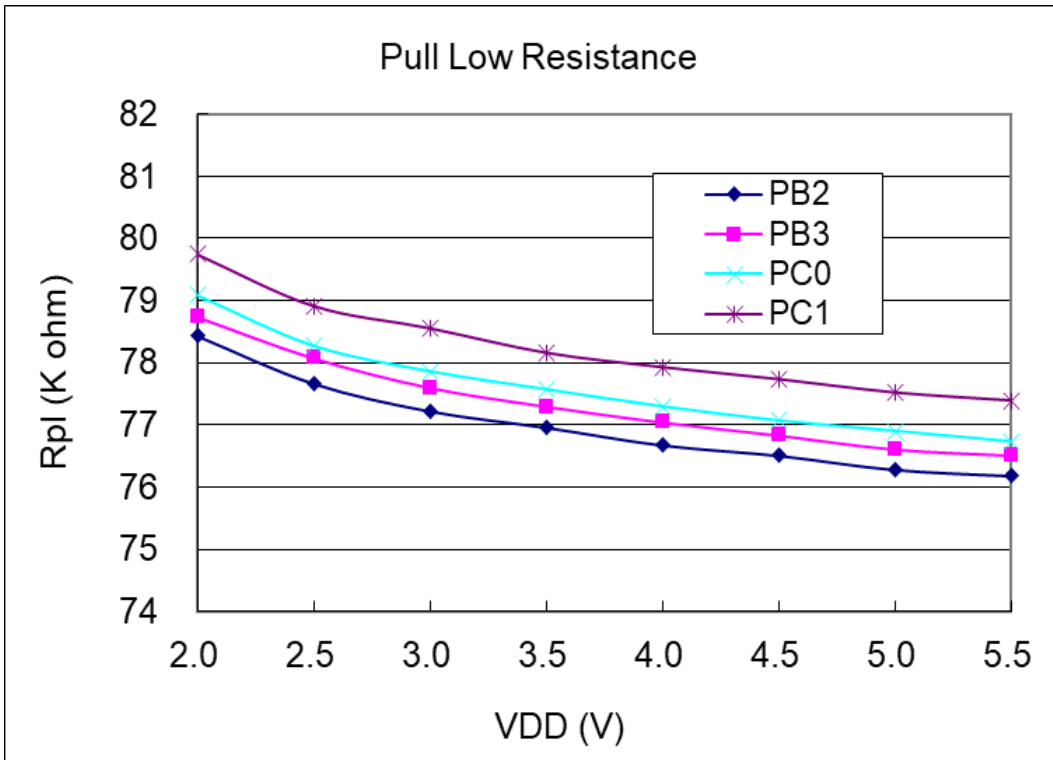

#### 4.15. Typical power down current ( $I_{PD}$ ) and power save current ( $I_{PS}$ )

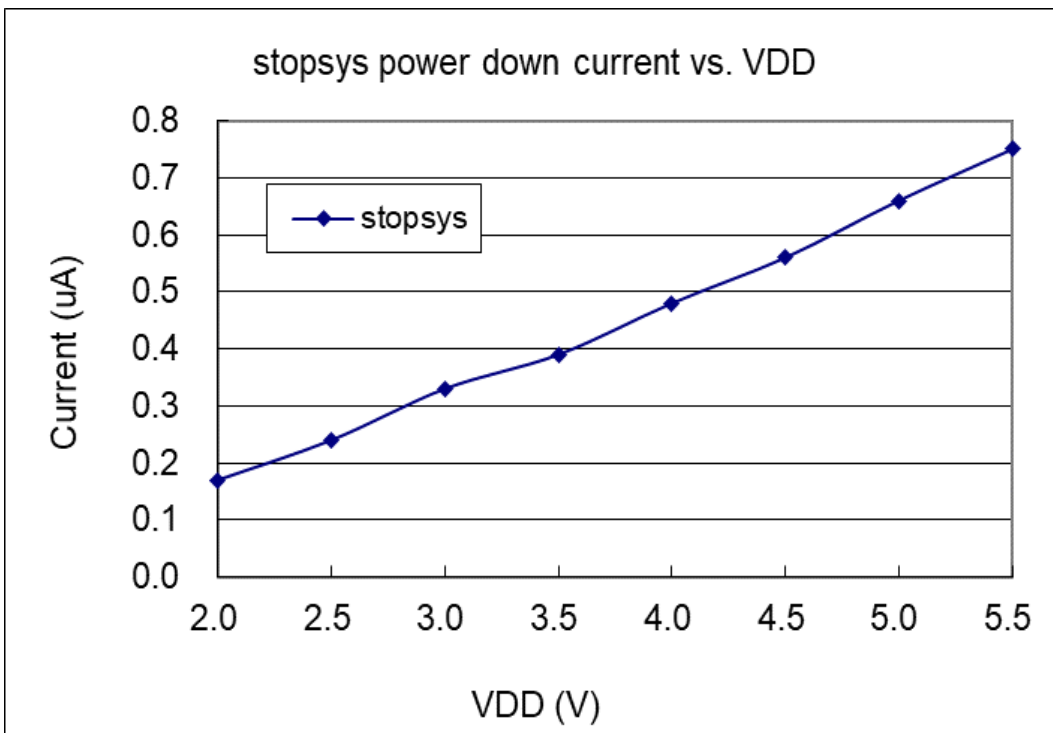

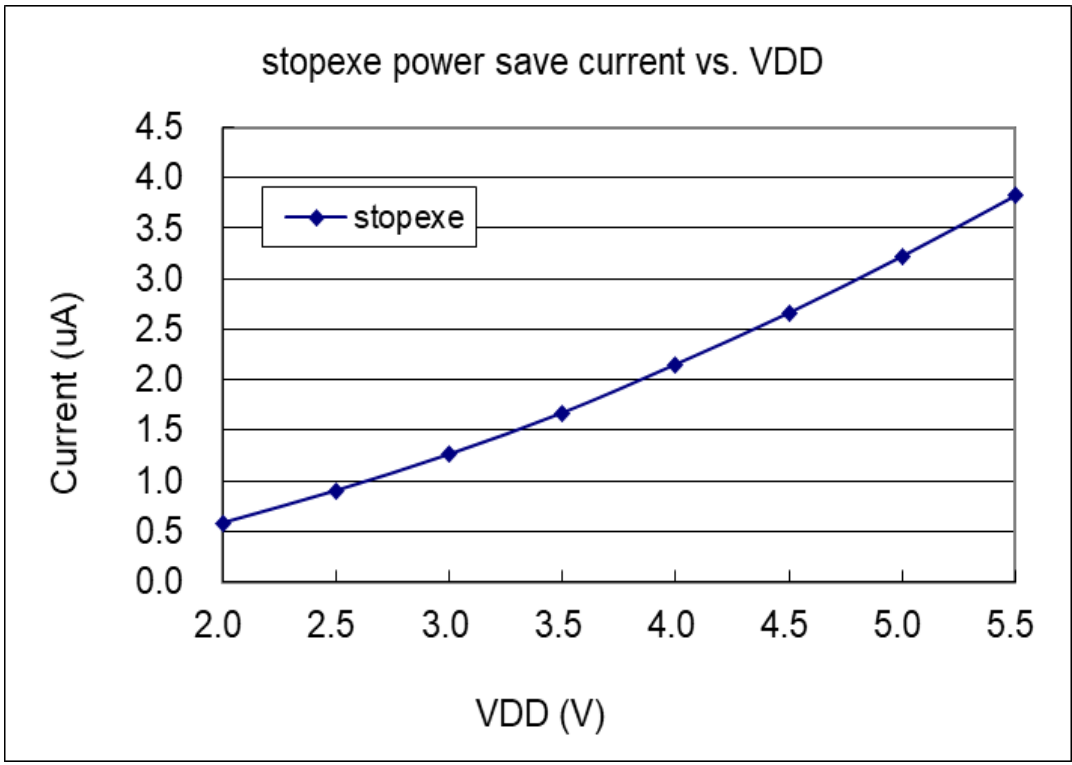

## 5. Functional Description

### 5.1. Program Memory - MTP

The MTP (Multiple Time Programmable) program memory is used to store the program instructions to be executed. The MTP program memory may contains the data, tables and interrupt entry. After reset, the program will start from the initial address 0x000 which is GOTO FPPA0 instruction usually. The interrupt entry is 0x10 if used, the last 32 addresses are reserved for system using, like checksum, serial number, etc. The MTP program memory for PFS123 is 3KW that is partitioned as Table 1. The MTP memory from address 0XBC0 to 0xBFF is for system using, address space from 0x001 to 0x00F and from 0x011 to 0XBFF are user program spaces.



Address	Function
0x000	GOTO FPPA0 instruction
0x001	User program
•	•
0x00F	User program
0x010	Interrupt entry address
0x011	User program
•	•
0xBBF	User program
0XBC0	System Using
•	•
0xBFF	System Using

Table 1: Program Memory Organization

### 5.2. Boot Procedure

POR (Power-On-Reset) is used to reset PFS123 when power up. The boot up time can be optional fast or normal. Customer must ensure the stability of supply voltage after power up no matter which option is chosen, the power up sequence is shown in the Fig. 1 and  $t_{SBP}$  is the boot up time.

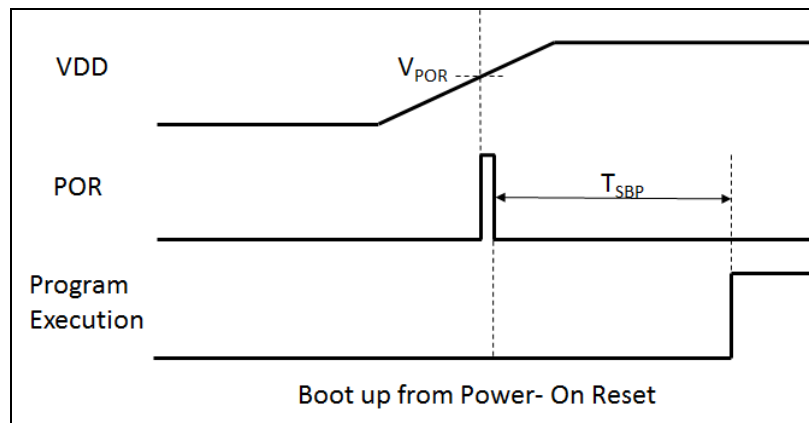
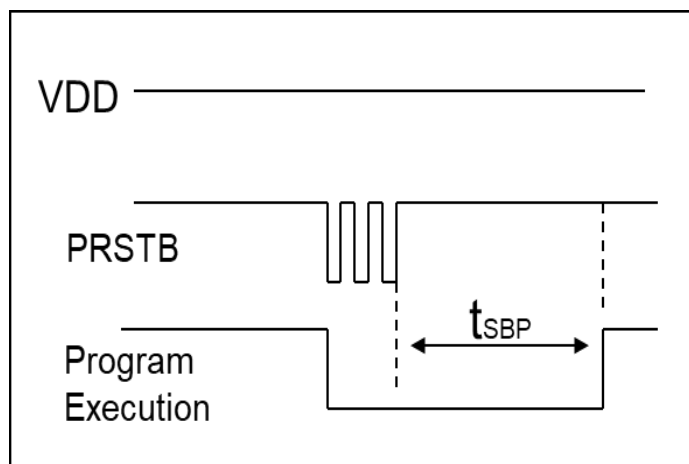
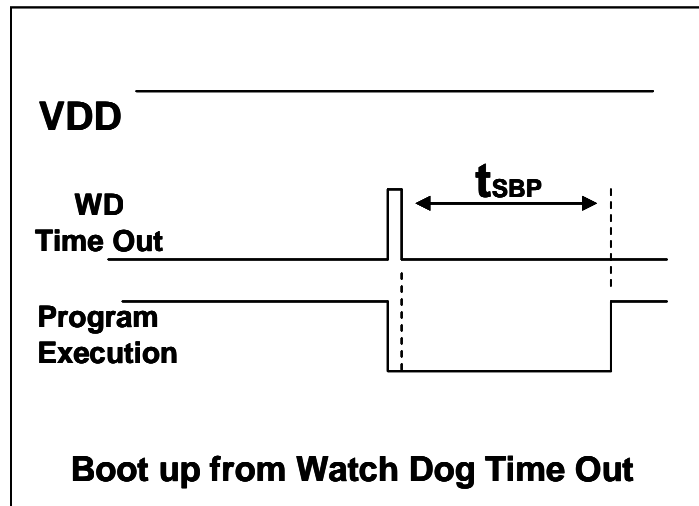
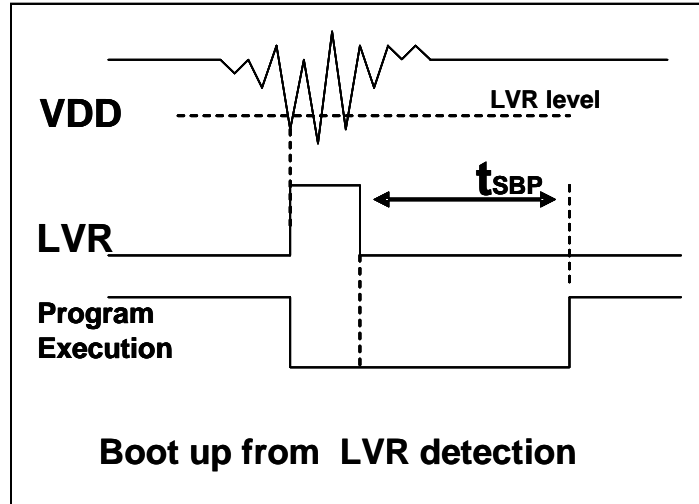

Fig.1: Power-Up Sequence

### 5.2.1. Timing charts for reset conditions



### 5.3. Data Memory - SRAM

The access of data memory can be byte or bit operation. Besides data storage, the SRAM data memory is also served as data pointer of indirect access method and the stack memory.

The stack memory is defined in the data memory. The stack pointer is defined in the stack pointer register; the depth of stack memory of each processing unit is defined by the user. The arrangement of stack memory fully flexible and can be dynamically adjusted by the user.

For indirect memory access mechanism, the data memory is used as the data pointer to address the data byte. All the data memory could be the data pointer; it's quite flexible and useful to do the indirect memory access. Since the data width is 8-bit, all the 256 bytes data memory of PFS123 can be accessed by indirect access mechanism.

### 5.4. Oscillator and clock

There are three oscillator circuits provided by PFS123: external crystal oscillator (EOSC), internal high RC oscillator (IHRC) and internal low RC oscillator (ILRC), and these three oscillators are enabled or disabled by registers `eoscr.7`, `clkmd.4` and `clkmd.2` independently. User can choose one of these three oscillators as system clock source and use ***clkmd*** register to target the desired frequency as system clock to meet different applications.

Oscillator Module	Enable/Disable
EOSC	<code>eoscr.7</code>
IHRC	<code>clkmd.4</code>
ILRC	<code>clkmd.2</code>

Table 2: Three oscillation circuits

#### 5.4.1. Internal High RC oscillator and Internal Low RC oscillator

After boot-up, the IHRC and ILRC oscillators are enabled. The frequency of IHRC can be calibrated to eliminate process variation by ***ihrcr*** register; normally it is calibrated to 16MHz. Please refer to the measurement chart for IHRC frequency verse  $V_{DD}$  and IHRC frequency verse temperature. The frequency of ILRC will vary by process, supply voltage and temperature, please refer to DC specification and do not use for accurate timing application.

#### 5.4.2. Chip calibration

The IHRC frequency and bandgap reference voltage may be different chip by chip due to manufacturing variation, PFS123 provide the IHRC frequency calibration to eliminate this variation, and this function can be selected when compiling user's program and the command will be inserted into user's program automatically. The calibration command is shown as below:

`.ADJUST_IC SYSCLK=IHRC/(p1), IHRC=(p2)MHz, VDD=(p3)V;`

Where, **p1**=2, 4, 8, 16, 32; In order to provide different system clock.

**p2**=14 ~ 18; In order to calibrate the chip to different frequency, 16MHz is the usually one.

**p3**=2.5 ~ 5.5; In order to calibrate the chip under different supply voltage.

### 5.4.3. IHRC Frequency Calibration and System Clock

During compiling the user program, the options for IHRC calibration and system clock are shown as Table 3:

SYSCLK	CLKMD	IHRCR	Description
○ Set IHRC / 2	= 34h (IHRC / 2)	Calibrated	IHRC calibrated to 16MHz, CLK=8MHz (IHRC/2)
○ Set IHRC / 4	= 14h (IHRC / 4)	Calibrated	IHRC calibrated to 16MHz, CLK=4MHz (IHRC/4)
○ Set IHRC / 8	= 3Ch (IHRC / 8)	Calibrated	IHRC calibrated to 16MHz, CLK=2MHz (IHRC/8)
○ Set IHRC / 16	= 1Ch (IHRC / 16)	Calibrated	IHRC calibrated to 16MHz, CLK=1MHz (IHRC/16)
○ Set IHRC / 32	= 7Ch (IHRC / 32)	Calibrated	IHRC calibrated to 16MHz, CLK=0.5MHz (IHRC/32)
○ Set ILRC	= E4h (ILRC / 1)	Calibrated	IHRC calibrated to 16MHz, CLK=ILRC
○ Disable	No change	No Change	IHRC not calibrated, CLK not changed

Table 3: Options for IHRC Frequency Calibration

Usually, .ADJUST\_IC will be the first command after boot up, in order to set the target operating frequency whenever starting the system. The program code for IHRC frequency calibration is executed only one time that occurs in writing the codes into MTP memory; after then, it will not be executed again. If the different option for IHRC calibration is chosen, the system status is also different after boot. The following shows the status of PFS123 for different option:

**(1)** .ADJUST\_IC    SYSCLK=IHRC/2, IHRC=16MHz, V<sub>DD</sub>=5V

After boot up, CLKMD = 0x34 :

- ◆ IHRC frequency is calibrated to 16MHz@V<sub>DD</sub>=5V and IHRC module is enabled
- ◆ System CLK = IHRC/2 = 8MHz
- ◆ Watchdog timer is disabled, ILRC is enabled, PA5 is in input mode

**(2)** .ADJUST\_IC    SYSCLK=IHRC/4, IHRC=16MHz, V<sub>DD</sub>=3.3V

After boot up, CLKMD = 0x14 :

- ◆ IHRC frequency is calibrated to 16MHz@V<sub>DD</sub>=3.3V and IHRC module is enabled
- ◆ System CLK = IHRC/4 = 4MHz
- ◆ Watchdog timer is disabled, ILRC is enabled, PA5 is in input mode

**(3)** .ADJUST\_IC    SYSCLK=IHRC/8, IHRC=16MHz, V<sub>DD</sub>=2.5V

After boot up, CLKMD = 0x3C :

- ◆ IHRC frequency is calibrated to 16MHz@V<sub>DD</sub>=2.5V and IHRC module is enabled
- ◆ System CLK = IHRC/8 = 2MHz
- ◆ Watchdog timer is disabled, ILRC is enabled, PA5 is in input mode

**(4)** .ADJUST\_IC    SYSCLK=IHRC/16, IHRC=16MHz, V<sub>DD</sub>=2.5V

After boot up, CLKMD = 0x1C :

- ◆ IHRC frequency is calibrated to 16MHz@V<sub>DD</sub>=2.5V and IHRC module is enabled
- ◆ System CLK = IHRC/16 = 1MHz
- ◆ Watchdog timer is disabled, ILRC is enabled, PA5 is in input mode

**(5)** .ADJUST\_IC    SYSCLK=IHRC/32, IHRC=16MHz, V<sub>DD</sub>=5V

After boot up, CLKMD = 0x7C :

- ◆ IHRC frequency is calibrated to 16MHz@V<sub>DD</sub>=5V and IHRC module is enabled
- ◆ System CLK = IHRC/32 = 500KHz
- ◆ Watchdog timer is disabled, ILRC is enabled, PA5 is in input mode

**(6) .ADJUST\_IC**    SYSCLK=ILRC, IHRC=16MHz, V<sub>DD</sub>=5V

After boot up, CLKMD = 0XE4 :

- ◆ IHRC frequency is calibrated to 16MHz@V<sub>DD</sub>=5V and IHRC module is disabled
- ◆ System CLK = ILRC
- ◆ Watchdog timer is disabled, ILRC is enabled, PA5 is input mode

**(7) .ADJUST\_IC**    DISABLE

After boot up, CLKMD is not changed (Do nothing) :

- ◆ IHRC is not calibrated and IHRC module is disabled
- ◆ System CLK = ILRC or IHRC/64
- ◆ Watchdog timer is enabled, ILRC is enabled, PA5 is in input mode

### 5.4.4. External Crystal Oscillator

If crystal oscillator is used, a crystal or resonator is required between X1 and X2. Fig.2 shows the hardware connection under this application; the range of operating frequency of crystal oscillator can be from 32 KHz to 4MHz, depending on the crystal placed on; higher frequency oscillator than 4MHz is NOT supported.

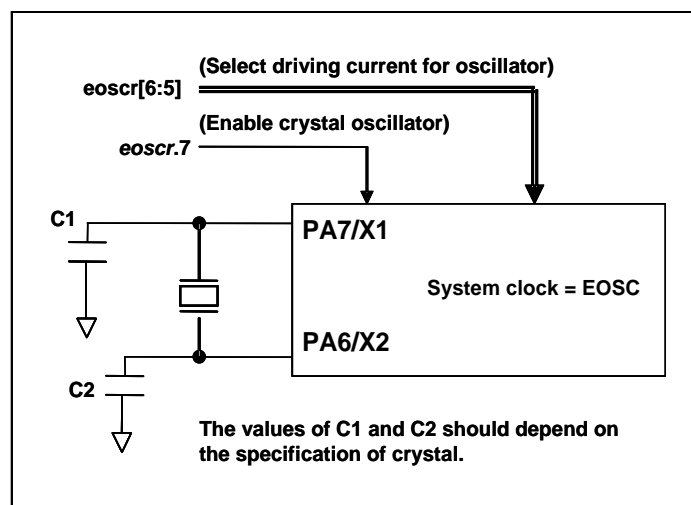

Fig.2: Connection of crystal oscillator

Besides crystal, external capacitor and options of PFS123 should be fine-tuned in *eoscr* (0x0a) register to have good sinusoidal waveform. The *eoscr.7* is used to enable crystal oscillator module, *eoscr.6* and *eoscr.5* are used to set the different driving current to meet the requirement of different frequency of crystal oscillator:

- ◆ *eoscr.[6:5]=01* : Low driving capability, for lower frequency, ex: 32KHz crystal oscillator
- ◆ *eoscr.[6:5]=10* : Middle driving capability, for middle frequency, ex: 1MHz crystal oscillator
- ◆ *eoscr.[6:5]=11* : High driving capability, for higher frequency, ex: 4MHz crystal oscillator

Table 4 shows the recommended values of C1 and C2 for different crystal oscillator; the measured start-up time under its corresponding conditions is also shown. Since the crystal or resonator had its own characteristic, the capacitors and start-up time may be slightly different for different type of crystal or resonator, please refer to its specification for proper values of C1 and C2.

Frequency	C1	C2	Measured Start-up time	Conditions
4MHz	4.7pF	4.7pF	6ms	( <i>eoscr</i> [6:5]=11, <i>misc</i> .6=0)
1MHz	10pF	10pF	11ms	( <i>eoscr</i> [6:5]=10, <i>misc</i> .6=0)
32KHz	22pF	22pF	450ms	( <i>eoscr</i> [6:5]=01, <i>misc</i> .6=0)

Table 4: Recommend values of C1 and C2 for crystal and resonator oscillators

When using the crystal oscillator, user must pay attention to the stable time of oscillator after enabling it, the stable time of oscillator will depend on frequency “crystal type” external capacitor and supply voltage. Before switching the system to the crystal oscillator, user must make sure the oscillator is stable; the reference program is shown as below:

```

void FPPA0 (void)
{
    . ADJUST_IC SYSCLK=IHRC/16, IHRC=16MHz, VDD=5V
    $ EOSCR Enable, 4MHz; // EOSCR = 0b111_00000;

    $ T16M EOSC, /1, BIT13; // T16 receive 2^14=16384 clocks of crystal EOSC,
    // Intrq.T16 =>1, crystal EOSC Is stable

    WORD count = 0;
    stt16 count;
    Intrq.T16 = 0;
    do
    { nop; }while(!Intrq.T16); // count from 0x0000 to 0x2000, then set INTRQ.T16
    clkmd= 0xB4; // switch system clock to EOSC;

    Clkmd.4 = 0; // disable IHRC

    ...

```

Please notice that the crystal oscillator should be fully turned off before entering the power-down mode, in order to avoid unexpected wakeup event.

### 5.4.5. System Clock and LVR level

The clock source of system clock comes from EOSC, IHRC and ILRC, the hardware diagram of system clock in the PFS123 is shown as Fig.3.

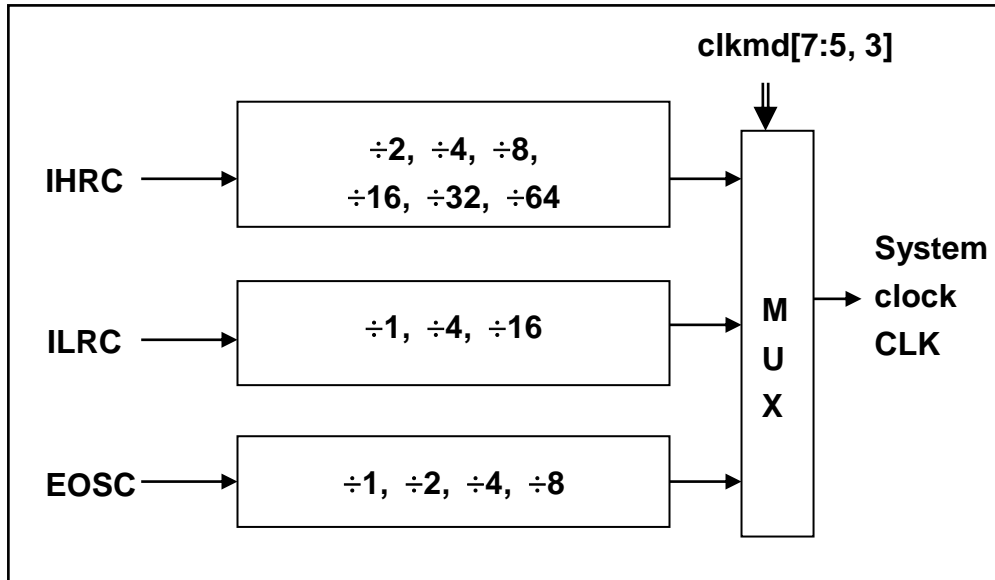

Fig.3: Options of System Clock

User can choose different operating system clock depends on its requirement; the selected operating system clock should be combined with supply voltage and LVR level to make system stable. The LVR level will be selected during compilation, and the lowest LVR levels can be chosen for different operating frequencies. Please refer to Section 4.1.

### 5.4.6. System Clock Switching

After IHRC calibration, user may want to switch system clock to a new frequency or may switch system clock at any time to optimize the system performance and power consumption. Basically, the system clock of PFS123 can be switched among IHRC, ILRC and EOSC by setting the **clkmd** register at any time; system clock will be the new one after writing to **clkmd** register immediately. Please notice that the original clock module can NOT be turned off at the same time as writing command to **clkmd** register. The examples are shown as below and more information about clock switching, please refer to the “Help” -> “Application Note” -> “IC Introduction” -> “Register Introduction” -> CLKMD”.

#### Case 1: Switching system clock from ILRC to IHRC/2

```

... // system clock is ILRC
CLKMD.4 = 1; // turn on IHRC first to improve anti-interference ability
CLKMD = 0x34 ; // switch to IHRC/2, ILRC CAN NOT be disabled here
// CLKMD.2 = 0 ; // if need, ILRC CAN be disabled at this time
...

```

#### Case 2: Switching system clock from ILRC to EOSC

```

... // system clock is ILRC
CLKMD = 0xA6 ; // switch to IHRC , ILRC CAN NOT be disabled here
CLKMD.2 = 0 ; // ILRC CAN be disabled at this time
...

```

#### Case 3: Switching system clock from IHRC/2 to ILRC

```

... // system clock is IHRC/2
CLKMD = 0xF4 ; // switch to ILRC , IHRC CAN NOT be disabled here
CLKMD.4 = 0 ; // IHRC CAN be disabled at this time
...

```

#### Case 4: Switching system clock from IHRC/2 to EOSC

```

... // system clock is IHRC/2
CLKMD = 0xB0 ; // switch to EOSC , IHRC CAN NOT be disabled here
CLKMD.4 = 0 ; // IHRC CAN be disabled at this time
...

```

#### Case 5: Switching system clock from IHRC/2 to IHRC/4

```

... // system clock is IHRC/2, ILRC is enabled here
CLKMD = 0X14 ; // switch to IHRC/4
...

```

#### Case 6: System may hang if it is to switch clock and turn off original oscillator at the same time

```

... // system clock is ILRC
CLKMD = 0x30 ; // CAN NOT switch clock from ILRC to IHRC/2 and
turn off ILRC oscillator at the same time

```



### 5.5. Comparator

One hardware comparator is built inside the PFS123; Fig.4 shows its hardware diagram. It can compare signals between two pins or with either internal reference voltage  $V_{internal R}$  or internal bandgap reference voltage. The two signals to be compared, one is the plus input and the other one is the minus input. For the minus input of comparator can be PA3, PA4, Internal bandgap 1.20 volt, PB6, PB7 or  $V_{internal R}$  selected by bit [3:1] of *gpcc* register, and the plus input of comparator can be PA4 or  $V_{internal R}$  selected by bit 0 of *gpcc* register. The output result can be enabled to output to PA0 directly, or sampled by Time2 clock (TM2\_CLK) which comes from Timer2 module. The output can be also inversed the polarity by bit 4 of *gpcc* register, the comparator output can be used to request interrupt service.

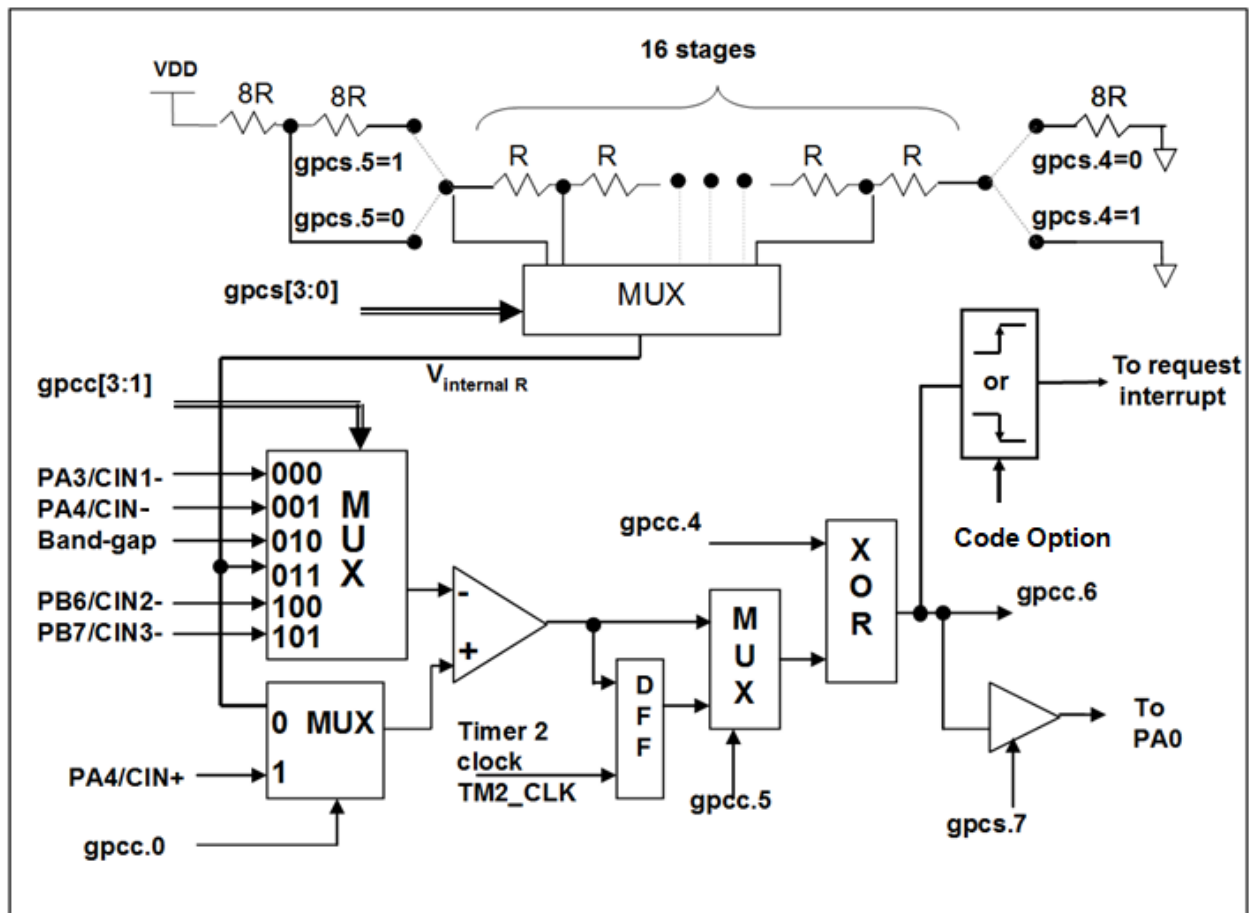

Fig.4: Hardware diagram of comparator

### 5.5.1 Internal reference voltage ( $V_{\text{internal R}}$ )

The internal reference voltage  $V_{\text{internal R}}$  is built by series resistance to provide different level of reference voltage, bit 4 and bit 5 of **gpcs** register are used to select the maximum and minimum values of  $V_{\text{internal R}}$  and bit [3:0] of **gpcs** register are used to select one of the voltage level which is divided-by-16 from the defined maximum level to minimum level. Fig.5 to Fig.8 shows four conditions to have different reference voltage  $V_{\text{internal R}}$ . By setting the **gpcs** register, the internal reference voltage  $V_{\text{internal R}}$  can be ranged from  $(1/32)*V_{\text{DD}}$  to  $(3/4)*V_{\text{DD}}$ .

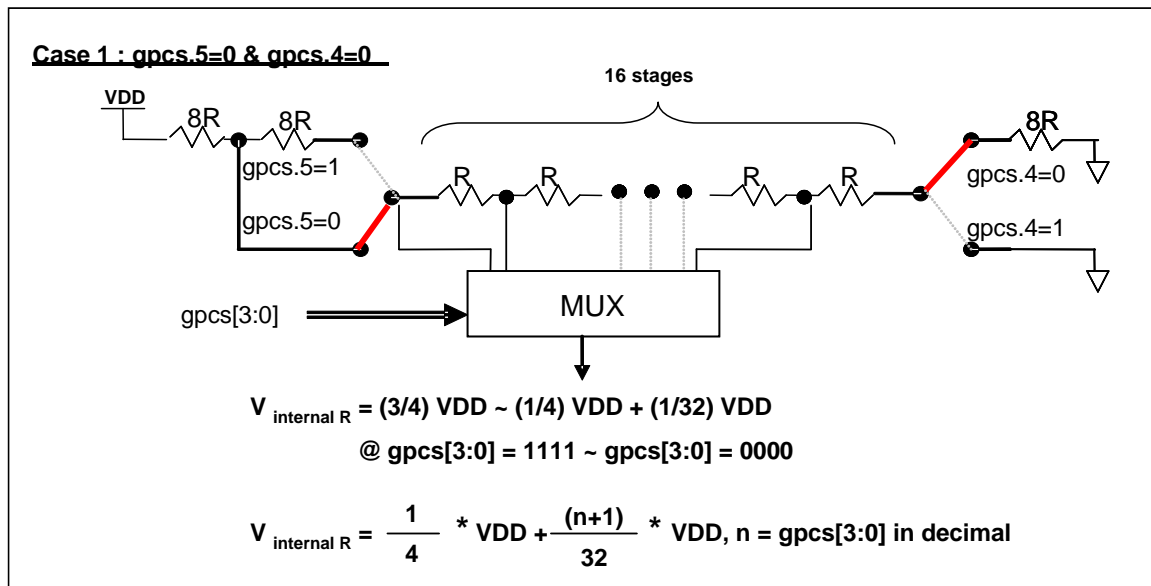

Fig.5:  $V_{\text{internal R}}$  hardware connection if gpcs.5=0 and gpcs.4=0

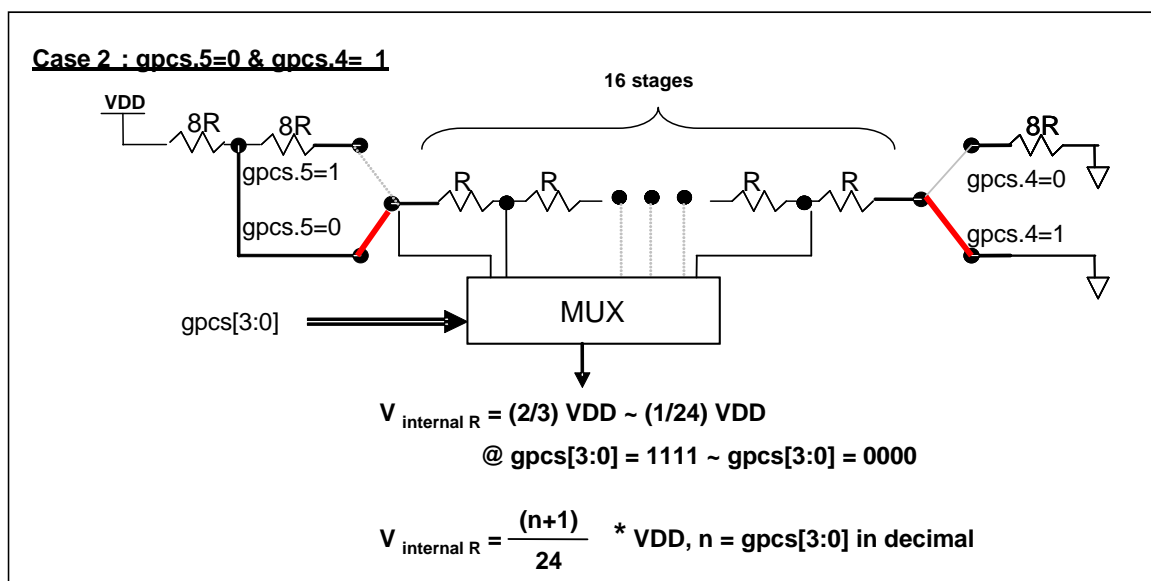

Fig.6:  $V_{\text{internal R}}$  hardware connection if gpcs.5=0 and gpcs.4=1

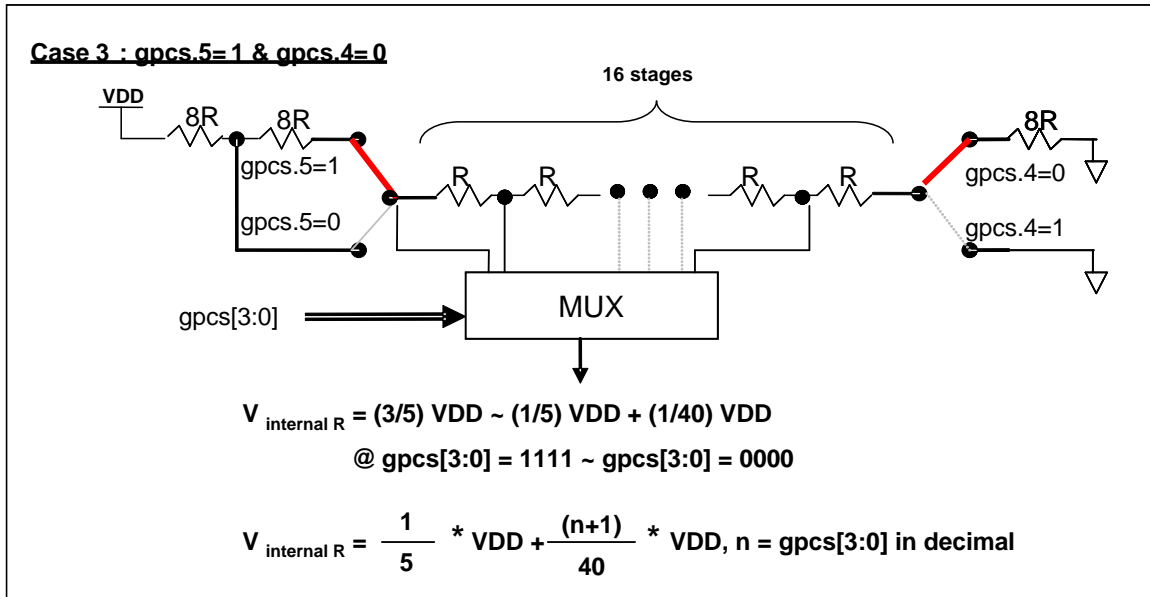

Fig.7:  $V_{\text{internal R}}$  hardware connection if gpcs.5=1 and gpcs.4=0

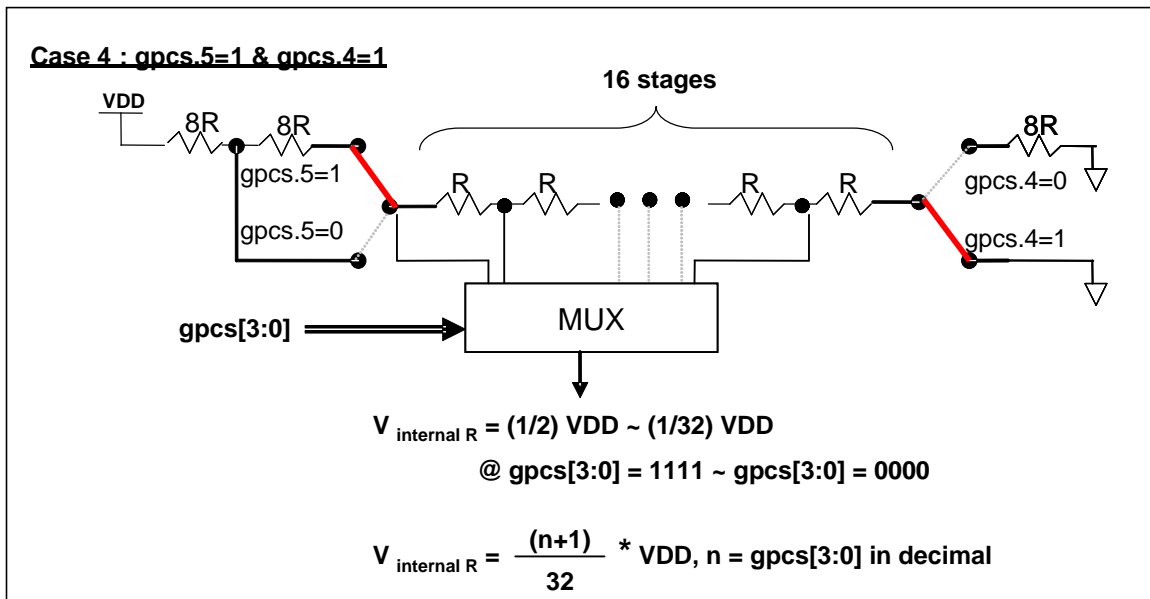

Fig.8:  $V_{\text{internal R}}$  hardware connection if gpcs.5=1 and gpcs.4=1

### 5.5.2 Using the comparator

#### Case 1:

Choosing PA3 as minus input and  $V_{internal R}$  with  $(18/32)*V_{DD}$  voltage level as plus input.  $V_{internal R}$  is configured as the above Figure “gpcs[5:4] = 2b'00” and gpcs [3:0] = 4b'1001 (n=9) to have  $V_{internal R} = (1/4)*V_{DD} + [(9+1)/32]*V_{DD} = [(9+9)/32]*V_{DD} = (18/32)*V_{DD}$ .

```

gpcs = 0b0_0_00_1001;           //  $V_{internal R} = V_{DD}*(18/32)$ 
gpcc = 0b1_0_0_0_000_0;         // enable comp, - input: PA3, + input:  $V_{internal R}$ 
padier = 0bxxxx_0_xxx;          // disable PA3 digital input to prevent leakage current

```

or

```

$ GPCS       $V_{DD}*18/32$ ;
$ GPCC      Enable, N_PA3, P_R; // - input: N_xx , + input: P_R( $V_{internal R}$ )
PADIER = 0bxxxx_0_xxx;

```

#### Case 2:

Choosing  $V_{internal R}$  as minus input with  $(22/40)*V_{DD}$  voltage level and PA4 as plus input, the comparator result will be inversed and then output to PA0.  $V_{internal R}$  is configured as the above Figure “gpcs[5:4] = 2b'10” and gpcs [3:0] = 4b'1101 (n=13) to have  $V_{internal R} = (1/5)*V_{DD} + [(13+1)/40]*V_{DD} = [(13+9)/40]*V_{DD} = (22/40)*V_{DD}$ .

```

gpcs = 0b1_0_10_1101;           // output to PA0,  $V_{internal R} = V_{DD}*(22/40)$ 
gpcc = 0b1_0_0_1_011_1;         // Inverse output, - input:  $V_{internal R}$ , + input: PA4
padier = 0bxxx_0_xxxx;          // disable PA4 digital input to prevent leakage current

```

or

```

$ GPCS      Output,  $V_{DD}*22/40$ ;
$ GPCC      Enable, Inverse, N_R, P_PA4; // - input: N_R( $V_{internal R}$ ) , + input: P_xx
PADIER = 0bxxx_0_xxxx;

```

**Note:** When selecting output to PA0 output, GPCS will affect the PA3 output function in ICE. Though the IC is fine, be careful to avoid this error during emulation.

### 5.5.3 Using the comparator and bandgap 1.20V

The internal bandgap module can provide 1.20 volt; it can measure the external supply voltage level. The bandgap 1.20 volt is selected as minus input of comparator and  $V_{\text{internal R}}$  is selected as plus input, the supply voltage of  $V_{\text{internal R}}$  is  $V_{\text{DD}}$ , the  $V_{\text{DD}}$  voltage level can be detected by adjusting the voltage level of  $V_{\text{internal R}}$  to compare with bandgap. If  $N$  (gpcs[3:0] in decimal) is the number to let  $V_{\text{internal R}}$  closest to bandgap 1.20 volt, the supply voltage  $V_{\text{DD}}$  can be calculated by using the following equations:

For using Case 1:  $V_{\text{DD}} = [ 32 / (N+9) ] * 1.20 \text{ volt ;}$

For using Case 2:  $V_{\text{DD}} = [ 24 / (N+1) ] * 1.20 \text{ volt ;}$

For using Case 3:  $V_{\text{DD}} = [ 40 / (N+9) ] * 1.20 \text{ volt ;}$

For using Case 4:  $V_{\text{DD}} = [ 32 / (N+1) ] * 1.20 \text{ volt ;}$

Case 1:

```

$ GPCS  $V_{\text{DD}} * 12 / 40$ ;           // 4.0V * 12/40 = 1.2V
$ GPCC Enable, BANDGAP, P_R;     // - input: BANDGAP, + input: P_R( $V_{\text{internal R}}$ )
....
if (GPC_Out)                      // or GPCC.6
{                                  // when  $V_{\text{DD}} > 4V$ 
}
else
{                                  // when  $V_{\text{DD}} < 4V$ 
}

```

### 5.6. VDD/2 LCD Bias Voltage Generator

There are five pins, PB0, PB1, PB2, PB5 and PB6, can be selected as the COM ports for LCD applications. By setting misc.4=1, these five COM ports are able to output VDD, VDD/2, GND three levels voltage.

A COM port can still output VDD & GND by selecting 1 or 0 for **pb.x** in output mode (**pb.c.x=1**) like a normal IO port. Additionally, a COM port can also output VDD/2 by switching it to input mode (**pb.c.x=0**). However, keep in mind to turn off the pull-high resistor **pbph.x** and **pbdir.x** to prevent the output voltage level from disturbing. Fig.9 shows how to use this function.

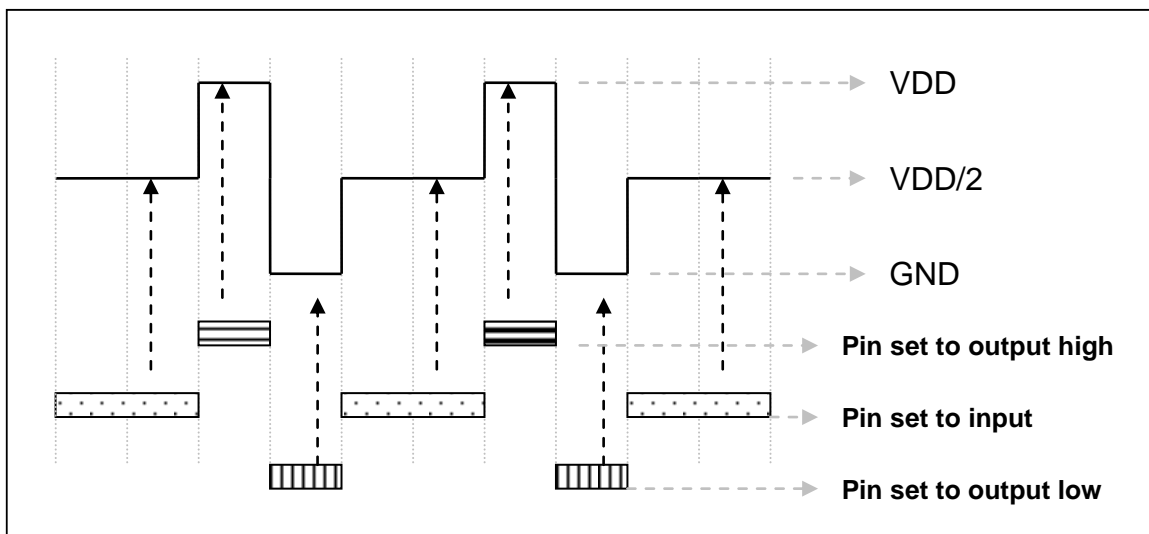

Fig. 9: Using VDD/2 LCD bias voltage generator

**Note:** ICE does NOT support the VDD/2 function of PB0.

### 5.7. 16-bit Timer (Timer16)

A 16-bit hardware timer (Timer16) is implemented in the PFS123, the clock sources of Timer16 may come from system clock (CLK), clock of external crystal oscillator (EOSC), internal high RC oscillator (IHRC), internal low RC oscillator (ILRC), PA4 and PA0, a multiplex is used to select clock output for the clock source. Before sending clock to the counter16, a pre-scaling logic with divided-by-1, 4, 16, and 64 is used for wide range counting. The 16-bit counter performs up-counting operation only, the counter initial values can be stored from memory by *stt16* instruction and the counting values can be loaded to memory by *ldt16* instruction. A selector is used to select the interrupt condition of Timer16, whenever overflow occurs, the Timer16 interrupt can be triggered. The hardware diagram of Timer16 is shown as Fig.10. The interrupt source of Timer16 comes from one of bit 8 to 15 of 16-bit counter, and the interrupt type can be rising edge trigger or falling edge trigger which is specified in the bit 5 of *integs* register (IO address 0x0C).

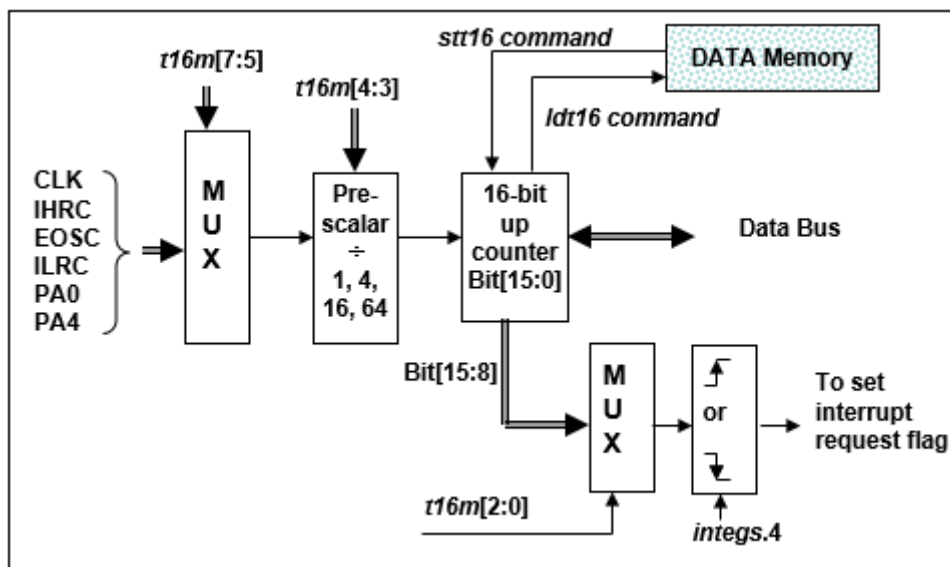

Fig.10: Hardware diagram of Timer16

When using the Timer16, the syntax for Timer16 has been defined in the .INC file. There are three parameters to define the Timer16; 1<sup>st</sup> parameter is used to define the clock source of Timer16, 2<sup>nd</sup> parameter is used to define the pre-scalar and the last one is to define the interrupt source. The detail description is shown as below:

```

T16M      IO_RW      0x06
$ 7~5: STOP, SYSCLK, X, PA4_F, IHRC, EOSC, ILRC, PA0_F // 1st par.
$ 4~3: /1, /4, /16, /64 // 2nd par.
$ 2~0: BIT8, BIT9, BIT10, BIT11, BIT12, BIT13, BIT14, BIT15 // 3d par.

```

User can define the parameters of T16M based on system requirement, some examples are shown below and more examples please refer to “Help → Application Note → IC Introduction → Register Introduction → T16M” in IDE utility.

**\$ T16M SYSCLK, /64, BIT15;**

*// choose (SYSCLK/64) as clock source, every 2<sup>16</sup> clock to set INTRQ.2=1*  
*// if using System Clock = IHRC / 2 = 8 MHz*  
*// SYSCLK/64 = 8 MHz/64 = 125KHz, about every 512 mS to generate INTRQ.2=1*

**\$ T16M EOSC, /1, BIT13;**

*// choose (EOSC/1) as clock source, every 2<sup>14</sup> clocks to generate INTRQ.2=1*  
*// if EOSC=32768 Hz, 32768 Hz/(2<sup>14</sup>) = 2Hz, every 0.5S to generate INTRQ.2=1*

**\$ T16M PA0\_F, /1, BIT8;**

*// choose PA0 as clock source, every 2<sup>9</sup> to generate INTRQ.2=1*  
*// receiving every 512 times PA0 to generate INTRQ.2=1*

**\$ T16M STOP;**

*// stop Timer16 counting*

If Timer16 is operated at free running, the frequency of interrupt can be described as below:

$$F_{INTRQ\_T16M} = F_{\text{clock source}} \div P \div 2^{n+1}$$

Where, F is the frequency of selected clock source to Timer16;

P is the selection of t16m [4:3]; (1, 4, 16, 64)

N is the n<sup>th</sup> bit selected to request interrupt service, for example: n=10 if bit 10 is selected.



### 5.8. 8-bit Timer (Timer2/Timer3) with PWM generation

Two 8-bit hardware timers (Timer2 and Timer3) with PWM generation are implemented in the PFS123. The following descriptions thereafter are for Timer2 only. It is because Timer3 have same structure with Timer2. Please refer to Fig.11 shown the hardware diagram of Timer2, the clock sources of Timer2 may come from system clock, internal high RC oscillator (IHRC), internal low RC oscillator (ILRC), external crystal oscillator (EOSC), PA0, PB0, PA4 and comparator. Bit [7:4] of register tm2c are used to select the clock of Timer2. If IHRC is selected for Timer2 clock source, the clock sent to Timer2 will keep running when using ICE in halt state. The output of Timer2 can be sent to pin PB2, PA3 or PB4, depending on bit [3:2] of tm2c register. A clock pre-scaling module is provided with divided-by- 1, 4, 16, and 64 options, controlled by bit [6:5] of tm2s register; one scaling module with divided-by-1~32 is also provided and controlled by bit [4:0] of tm2s register. In conjunction of pre-scaling function and scaling function, the frequency of Timer2 clock (TM2\_CLK) can be wide range and flexible.

The Timer2 counter performs 8-bit up-counting operation only; the counter values can be set or read back by tm2ct register. The 8-bit counter will be clear to zero automatically when its values reach for upper bound register, the upper bound register is used to define the period of timer or duty of PWM. There are two operating modes for Timer2: period mode and PWM mode; period mode is used to generate periodical output waveform or interrupt event; PWM mode is used to generate PWM output waveform with optional 6-bit to 8-bit PWM resolution, Fig.12 shows the timing diagram of Timer2 for both period mode and PWM mode.

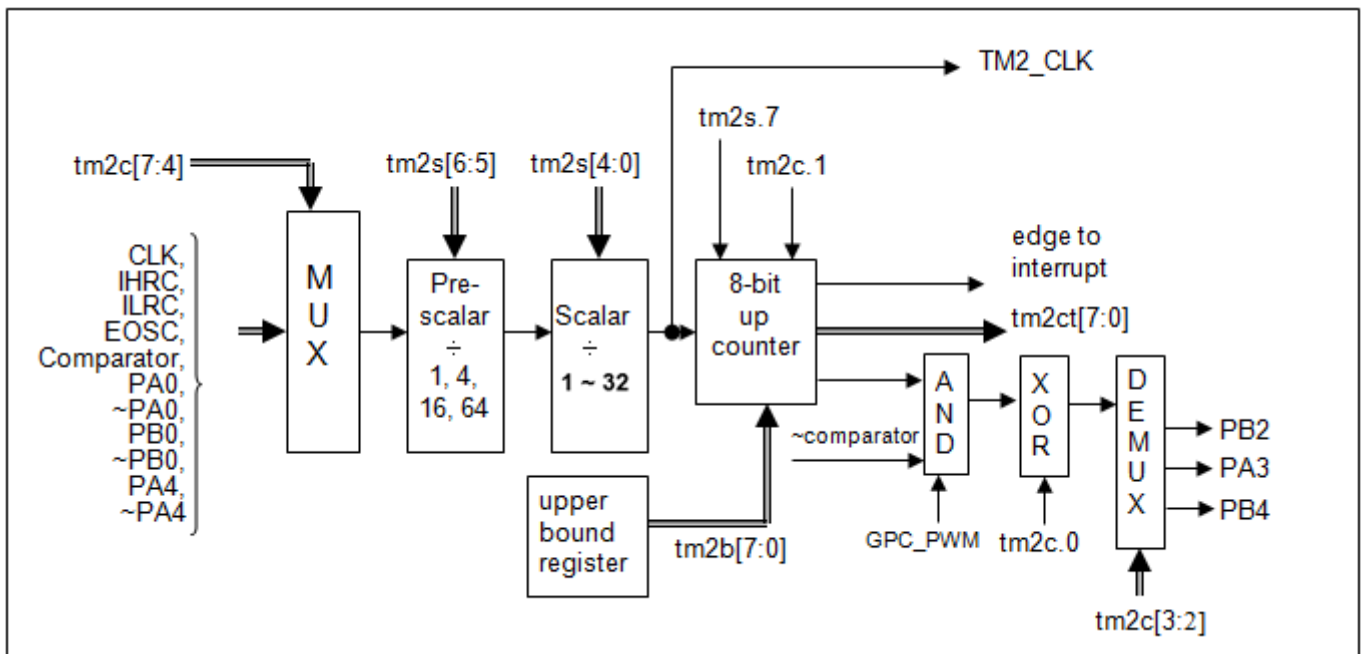

Fig.11: Timer2 hardware diagram

The output of Timer3 can be sent to pin PB5, PB6 or PB7.

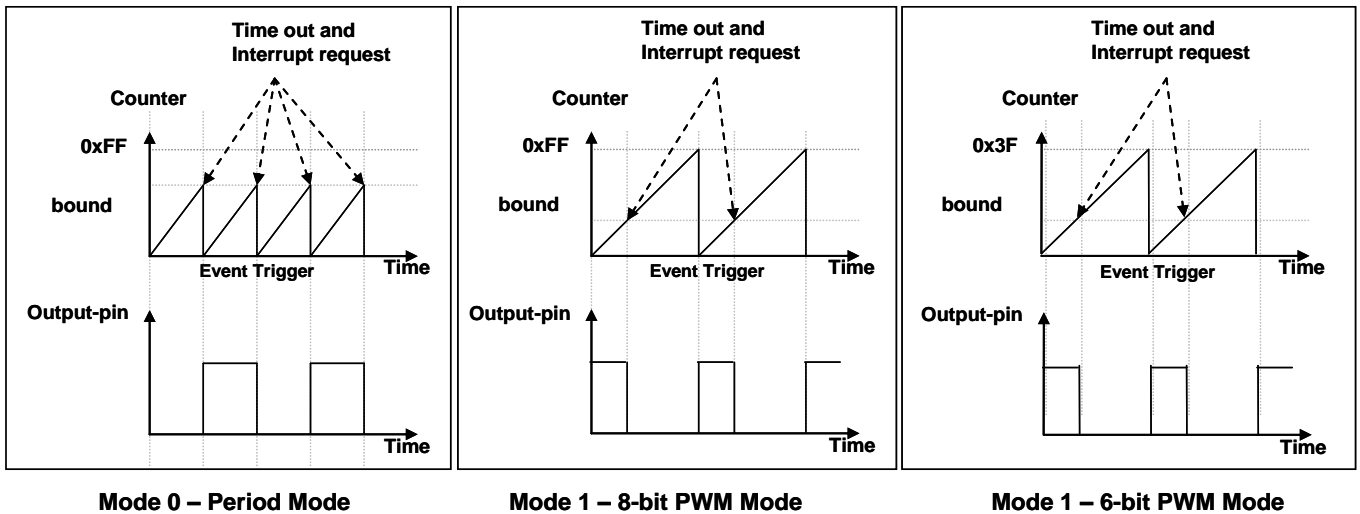

Fig.12: Timing diagram of Timer2 in period mode and PWM mode (tm2c.1=1)

A Code Option GPC\_PWM is for the applications which need the generated PWM waveform to be controlled by the comparator result. If the Code Option GPC\_PWM is selected, the PWM output stops while the comparator output is 1 and then the PWM output turns on while the comparator output goes back to 0, as shown in Fig. 13.

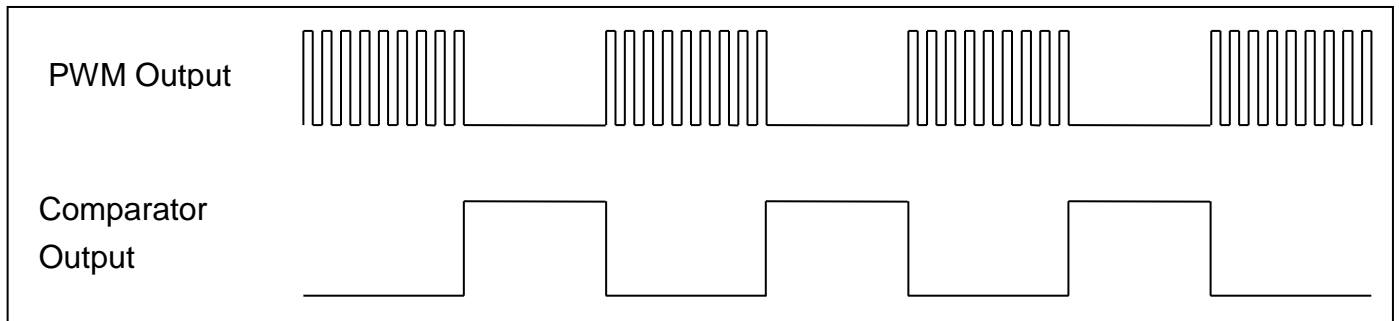

Fig.13 : Comparator controls the output of PWM waveform

### 5.8.1 Using the Timer2 to generate periodical waveform

If periodical mode is selected, the duty cycle of output is always 50%; its frequency can be summarized as below:

$$\text{Frequency of Output} = Y \div [2 \times (K+1) \times S1 \times (S2+1) ]$$

Where,  $Y = \text{tm2c}[7:4]$  : frequency of selected clock source

$K = \text{tm2b}[7:0]$  : bound register in decimal

$S1 = \text{tm2s}[6:5]$  : pre-scalar ( $S1 = 1, 4, 16, 64$ )

$S2 = \text{tm2s}[4:0]$  : scalar register in decimal ( $S2 = 0 \sim 31$ )

Example 1:

tm2c = 0b0001\_1000, Y=8MHz

tm2b = 0b0111\_1111, K=127

tm2s = 0b0\_00\_00000, S1=1, S2=0

➔ frequency of output =  $8\text{MHz} \div [ 2 \times (127+1) \times 1 \times (0+1) ] = 31.25\text{KHz}$

Example 2:

tm2c = 0b0001\_1000, Y=8MHz

tm2b = 0b0111\_1111, K=127

tm2s[7:0] = 0b0\_11\_11111, S1=64 , S2 = 31

➔ frequency =  $8\text{MHz} \div ( 2 \times (127+1) \times 64 \times (31+1) ) = 15.25\text{Hz}$

Example 3:

tm2c = 0b0001\_1000, Y=8MHz

tm2b = 0b0000\_1111, K=15

tm2s = 0b0\_00\_00000, S1=1, S2=0

➔ frequency =  $8\text{MHz} \div ( 2 \times (15+1) \times 1 \times (0+1) ) = 250\text{KHz}$

Example 4:

tm2c = 0b0001\_1000, Y=8MHz

tm2b = 0b0000\_0001, K=1

tm2s = 0b0\_00\_00000, S1=1, S2=0

➔ frequency =  $8\text{MHz} \div ( 2 \times (1+1) \times 1 \times (0+1) ) = 2\text{MHz}$

The sample program for using the Timer2 to generate periodical waveform from PA3 is shown as below:

```

Void FPPA0 (void)
{
    . ADJUST_IC   SYSCLK=IHRC/2, IHRC=16MHz, VDD=5V
    ...
    tm2ct = 0x00;
    tm2b = 0x7f;
    tm2s = 0b0_00_00001;           // 8-bit PWM, pre-scalar = 1, scalar = 2
    tm2c = 0b0001_10_0_0;         // system clock, output=PA3, period mode
    while(1)
    {
        nop;
    }
}

```

### 5.8.2 Using the Timer2 to generate 8-bit PWM waveform

If 8-bit PWM mode is selected, it should set  $tm2c[1]=1$  and  $tm2s[7]=0$ , the frequency and duty cycle of output waveform can be summarized as below:

$$\text{Frequency of Output} = Y \div [256 \times S1 \times (S2+1) ]$$

$$\text{Duty of Output} = [( K + 1 ) \div 256] \times 100\%$$

Where,       $Y = tm2c[7:4]$  : frequency of selected clock source  
                $K = tm2b[7:0]$  : bound register in decimal  
                $S1 = tm2s[6:5]$  : pre-scalar ( $S1 = 1, 4, 16, 64$ )  
                $S2 = tm2s[4:0]$  : scalar register in decimal ( $S2 = 0 \sim 31$ )

Example 1:

$tm2c = 0b0001\_1010$ ,  $Y=8MHz$   
 $tm2b = 0b0111\_1111$ ,  $K=127$   
 $tm2s = 0b0\_00\_00000$ ,  $S1=1$ ,  $S2=0$   
 → frequency of output =  $8MHz \div ( 256 \times 1 \times (0+1) ) = 31.25KHz$   
 → duty of output =  $[(127+1) \div 256] \times 100\% = 50\%$

Example 2:

$tm2c = 0b0001\_1010$ ,  $Y=8MHz$   
 $tm2b = 0b0111\_1111$ ,  $K=127$   
 $tm2s = 0b0\_11\_11111$ ,  $S1=64$ ,  $S2=31$   
 → frequency of output =  $8MHz \div ( 256 \times 64 \times (31+1) ) = 15.25Hz$   
 → duty of output =  $[(127+1) \div 256] \times 100\% = 50\%$

Example 3:

$tm2c = 0b0001\_1010$ ,  $Y=8MHz$   
 $tm2b = 0b1111\_1111$ ,  $K=255$   
 $tm2s = 0b0\_00\_00000$ ,  $S1=1$ ,  $S2=0$   
 → PWM output keep high  
 → duty of output =  $[(255+1) \div 256] \times 100\% = 100\%$

Example 4:

$tm2c = 0b0001\_1010$ ,  $Y=8MHz$   
 $tm2b = 0b0000\_1001$ ,  $K = 9$   
 $tm2s = 0b0\_00\_00000$ ,  $S1=1$ ,  $S2=0$   
 → frequency of output =  $8MHz \div ( 256 \times 1 \times (0+1) ) = 31.25KHz$   
 → duty of output =  $[(9+1) \div 256] \times 100\% = 3.9\%$

The sample program for using the Timer2 to generate PWM waveform from PA3 is shown as below:

```

void  FPPA0 (void)
{
    .ADJUST_IC    SYSCLK=IHRC/2, IHRC=16MHz, VDD=5V
    tm2ct = 0x00;
    tm2b = 0x7f;
    tm2s = 0b0_00_00001;           //    8-bit PWM, pre-scalar = 1, scalar = 2
    tm2c = 0b0001_10_1_0;         //    system clock, output=PA3, PWM mode
    while(1)
    {
        nop;
    }
}

```

### 5.8.3 Using the Timer2 to generate 6-bit PWM waveform

If 6-bit PWM mode is selected, it should set **tm2c[1]=1** and **tm2s[7]=1**, the frequency and duty cycle of output waveform can be summarized as below:

$$\text{Frequency of Output} = Y \div [64 \times S1 \times (S2+1) ]$$

$$\text{Duty of Output} = [( K + 1 ) \div 64] \times 100\%$$

Where, tm2c[7:4] = Y : frequency of selected clock source

tm2b[7:0] = K : bound register in decimal

tm2s[6:5] = S1 : pre-scalar (S1= 1, 4, 16, 64)

tm2s[4:0] = S2 : scalar register in decimal (S2= 0 ~ 31)

Users can set Timer2 to be 7-bit PWM mode instead of 6-bit mode by using **TMx\_Bit** code option. At that time, the calculation factors of the above equations become 128 instead of 64.

#### Example 1:

tm2c = 0b0001\_1010, Y=8MHz

tm2b = 0b0001\_1111, K=31

tm2s = 0b1\_00\_00000, S1=1, S2=0

→ frequency of output = 8MHz ÷ ( 64 × 1 × (0+1) ) = 125KHz

→ duty = [(31+1) ÷ 64] × 100% = 50%

#### Example 2:

tm2c = 0b0001\_1010, Y=8MHz

tm2b = 0b0001\_1111, K=31

tm2s = 0b1\_11\_11111, S1=64, S2=31

→ frequency of output = 8MHz ÷ ( 64 × 64 × (31+1) ) = 61.03 Hz

→ duty of output = [(31+1) ÷ 64] × 100% = 50%

Example 3:

```

tm2c = 0b0001_1010, Y=8MHz
tm2b = 0b0011_1111, K=63
tm2s = 0b1_00_00000, S1=1, S2=0
→ PWM output keep high
→ duty of output = [(63+1) ÷ 64] × 100% = 100%
    
```

Example 4:

```

tm2c = 0b0001_1010, Y=8MHz
tm2b = 0b0000_0000, K=0
tm2s = 0b1_00_00000, S1=1, S2=0
→ frequency = 8MHz ÷ ( 64 × 1 × (0+1) ) = 125KHz
→ duty = [(0+1) ÷ 64] × 100% =1.5%
    
```

### 5.9. 11-bit PWM Generator

One set of triple 11-bit SuLED (Super LED) hardware PWM generator is implemented in the PFS123. It consists of three PWM generators (LPWMG0, LPWMG1 & LPWMG2). Their individual outputs are listed as below:

- LPWMG0 – PA0, PB4, PB5, PC2, PB6 (available if LPWMG1 doesn't select PB6)
- LPWMG1 – PA4, PB6, PB7, PC3
- LPWMG2 – PA3, PB2, PB3, PA5 (open drain output only), PC0, PB5 (available if LPWMG0 doesn't select PB5)

**Note:** 5S-I-S01/2(B) doesn't support the function of the set of 11-bit SuLED hardware PWM generators.

#### 5.9.1 PWM Waveform

A PWM output waveform (Fig.14) has a time-base ( $T_{\text{Period}} = \text{Time of Period}$ ) and a time with output high level (Duty Cycle). The frequency of the PWM output is the inverse of the period ( $f_{\text{PWM}} = 1/T_{\text{Period}}$ ).

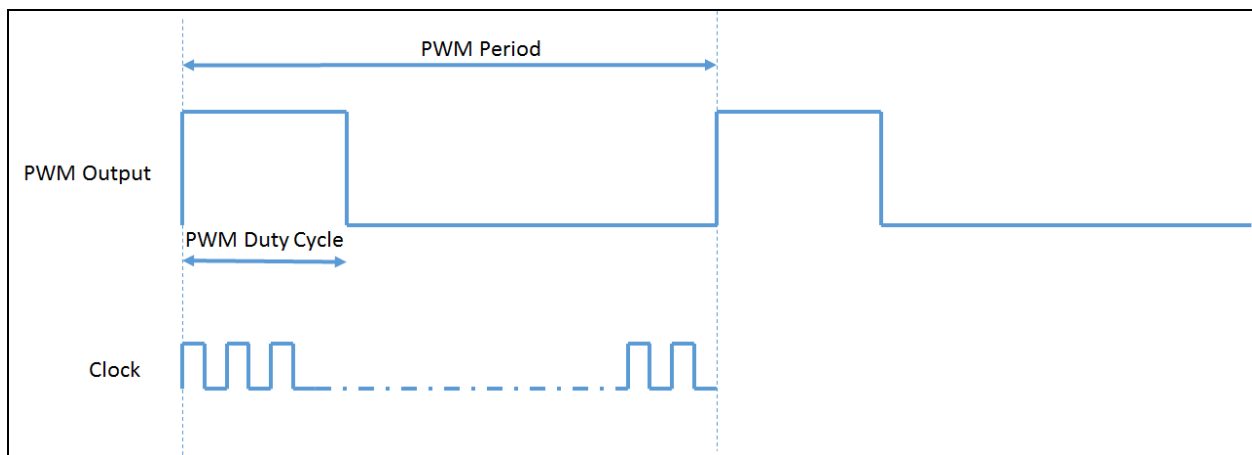

Fig.14: PWM Output Waveform

### 5.9.2 Hardware Diagram

Fig.15 shows the hardware diagram of the whole set of SuLED 11-bit hardware PWM generators. Those three PWM generators use a common Up-Counter and clock source selector to create the time base, and so the start points (the rising edge) of the PWM cycle are synchronized. The clock source can be IHRC or system clock. The PWM signal output pins that can be selected via *lpwmgxc* register selection. The period of PWM waveform is defined by the common PWM upper bound high and low registers, and the duty cycle of individual PWM waveform is defined by the individual set in the PWM duty high and low registers.

The additional OR and XOR logic of LPWMG0 channel is used to create the complementary switching waveforms with dead zone control. Selecting code option GPC\_PWM can also control the generated PWM waveform by the comparator result.

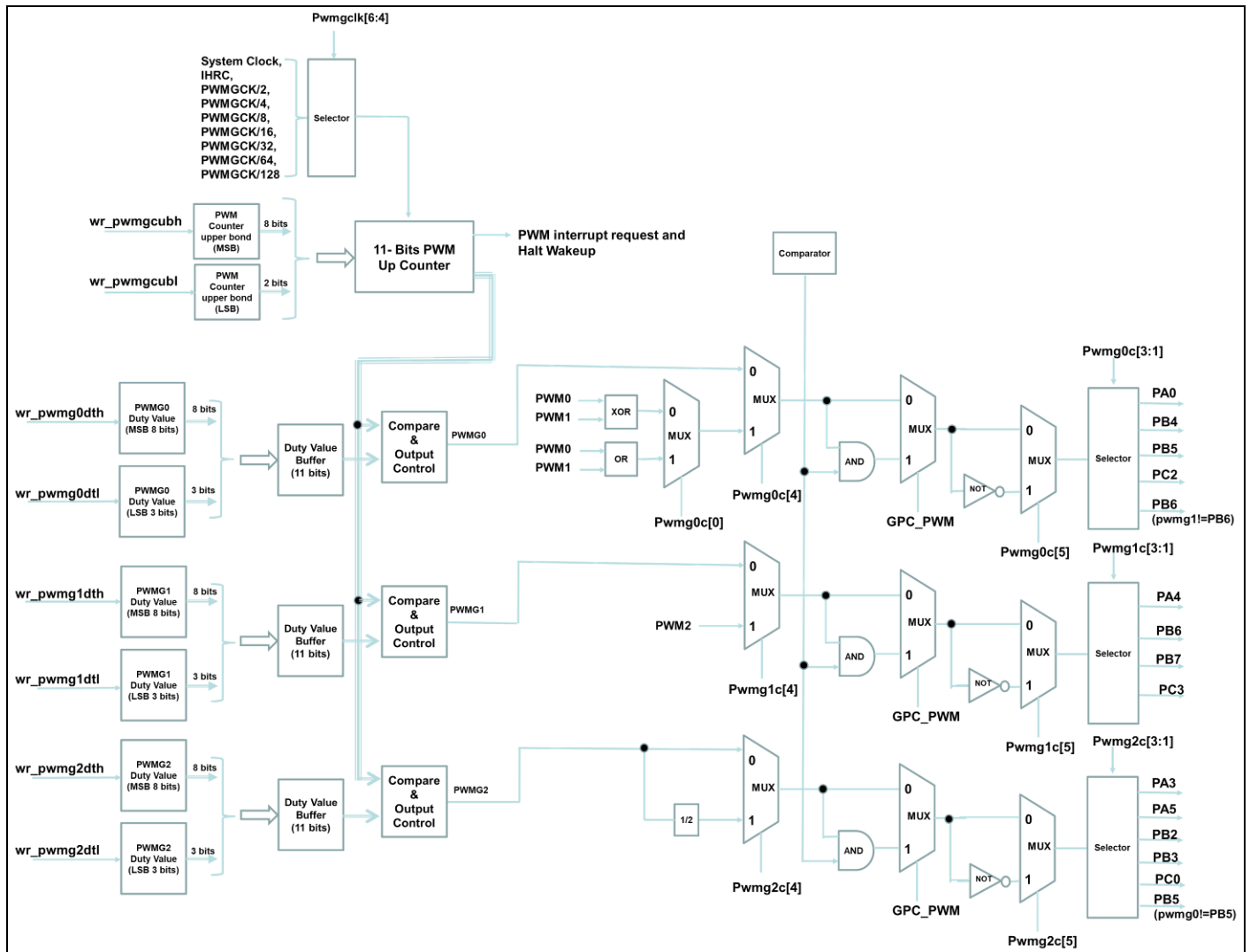

Fig.15: Hardware diagram of whole set of triple SuLED 11-bit PWM generators

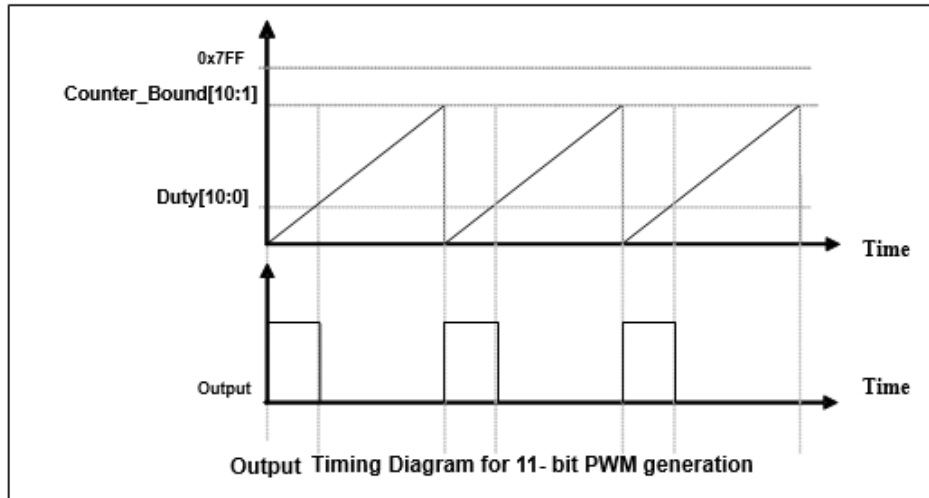

Fig.16: Output Timing Diagram of 11-bit PWM Generator

### 5.9.3 Equations for 11-bit PWM Generator

$$\text{PWM Frequency } F_{\text{PWM}} = F_{\text{clock source}} \div [ P \times (\text{CB10\_1} + 1) ]$$

$$\text{PWM Duty(in time)} = (1 / F_{\text{PWM}}) \times (\text{DB10\_1} + \text{DB0} \times 0.5 + 0.5) \div (\text{CB10\_1} + 1)$$

$$\text{PWM Duty(in percentage)} = (\text{DB10\_1} + \text{DB0} \times 0.5 + 0.5) \div (\text{CB10\_1} + 1) \times 100\%$$

Where,

$P = \text{LPWMGCLK}[6:4]$ ; pre-scalar  $P = 1, 2, 4, 8, 16, 32, 64, 128$

$\text{DB10\_1} = \text{Duty\_Bound}[10:1] = \{ \text{LPWMGxDTH}[7:0], \text{LPWMGxDTL}[7:6] \}$ , duty bound

$\text{DB0} = \text{Duty\_Bound}[0] = \text{LPWMGxDTL}[5]$

$\text{CB10\_1} = \text{Counter\_Bound}[10:1] = \{ \text{LPWMGCUBH}[7:0], \text{LPWMGCUBL}[7:6] \}$ , counter bound



### 5.9.4 PWM Waveforms with Complementary Dead Zones

Based on the specific 11 bit PWM architecture of PFS123, here we employ PWM2 output and PWM0 inverse output after PWM0 xor PWM1 to generate two PWM waveforms with complementary dead zones.

Example program is as follows:

```

#define  dead_zone          10           //  dead time = 10% * (1/PWM_Frequency) us
#define  PWM_Pulse          50           //  set 50% as PWM duty cycle

#define  PWM_Pulse_1        35           //  set 35% as PWM duty cycle
#define  PWM_Pulse_2        60           //  set 60% as PWM duty cycle
#define  switch_time        400*2       //  adjusting switch time
//Note: To avoid noise, switch_time must be a multiple of PWM period. In this example PWM period = 400us,
//so switch_time = 400*2 us.
void FPPA0 (void)
{
  .ADJUST_IC    SYSCLK=IHRC/16, IHRC=16MHz, VDD=5V;
  /****** Generating fixed duty cycle waveform *****
  //----- Set the counter upper bound and duty cycle -----
  LPWMG0DTL    =    0x00;
  LPWMG0DTH    =    PWM_Pulse + dead_zone;

  LPWMG1DTL    =    0x00;
  LPWMG1DTH    =    dead_zone;           // After LPWMG0 xor LPWMG, PWM duty
                                           // cycle=PWM_Pulse%

  LPWMG2DTL    =    0x00;
  LPWMG2DTH    =    PWM_Pulse + dead_zone*2;

  LPWMGCUBL    =    0x00;
  LPWMGCUBH    =    100;
  //---- Configure clock and pre-scalar -----
  $ LPWMGCLK    Enable, /1, sysclk;
  //----- Output control -----
  $ LPWMG0C     Enable,Inverse,PWM_Gen,PA0,gen_xor;   // After LPWMG0 xor LPWMG,
                                                         // output the inversed waveform through PA0
  $ LPWMG1C     Enable, LPWMG1,disable;             // disable LPWMG1 output
  $ LPWMG2C     Enable, PA3;                       // output LPWMG2 waveform through PA3

  while(1)
  {
    /****** Switching duty cycle *****
    // To avoid the possible instant disappearance of dead zone, user should comply with the following
    // instruction sequence.
    // When increase the duty cycle: 50%/60% → 35%

```

```

LPWMG0DTL    =    0x00;
LPWMG0DTH    =    PWM_Pulse_1 + dead_zone;
LPWMG2DTL    =    0x00;
LPWMG2DTH    =    PWM_Pulse_1 + dead_zone*2;
.delay    switch_time
// When decrease the duty cycle: 35% → 60%
LPWMG2DTL    =    0x00;
LPWMG2DTH    =    PWM_Pulse_2 + dead_zone*2;
LPWMG0DTL    =    0x00;
LPWMG0DTH    =    PWM_Pulse_2 + dead_zone;
.delay    switch_time
}
}

```

The following figures show the waveforms at different condition.

1. The PWM waveform in a fixed-duty cycle:

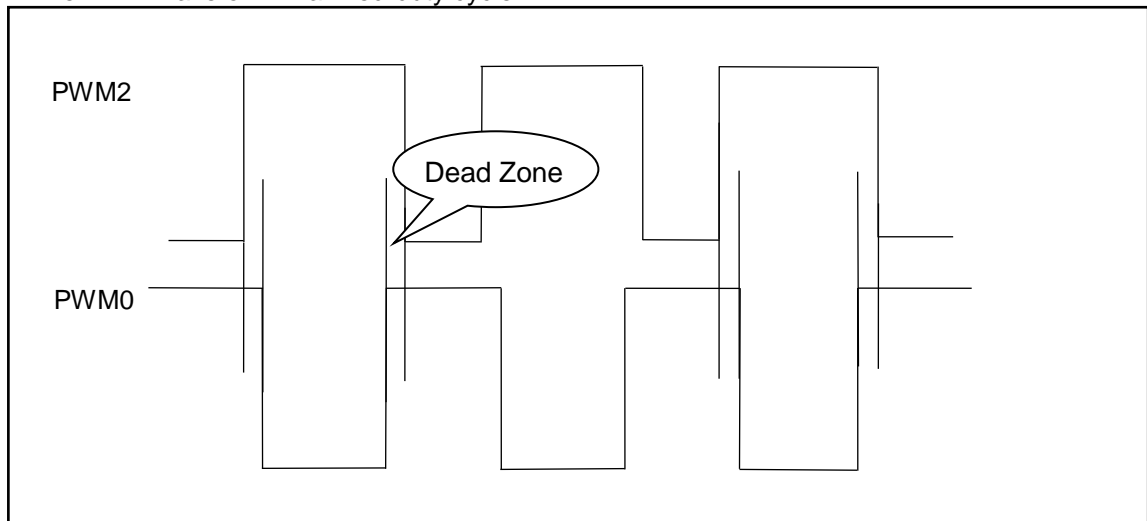

Fig.17: Complementary PWM waveform with dead zones

2. PWM waveform when switching two duty cycles:

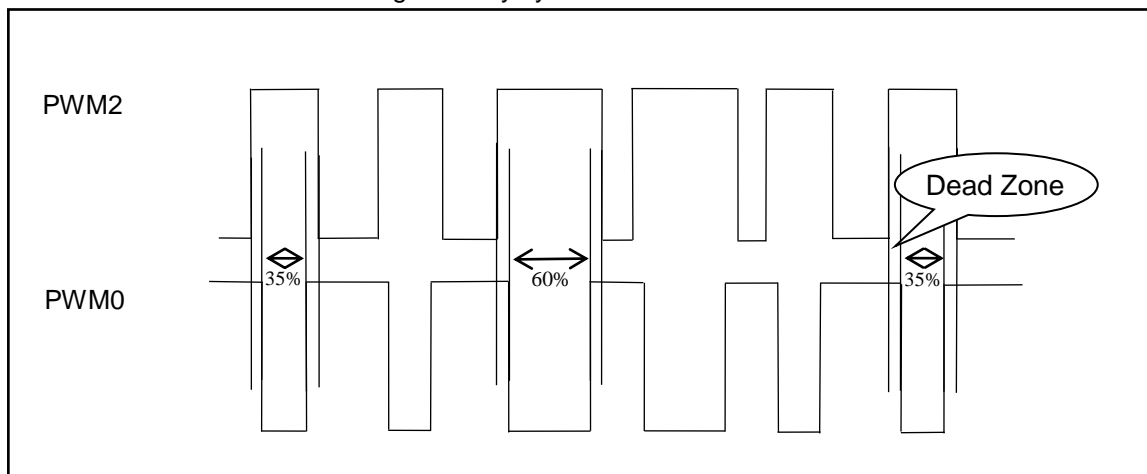

Fig.17: Two complementary PWM waveforms

User can find that above example only provides dead zone where PWM are both in high. If need dead zone where PWM are both in low, you can realize it by resetting each control register's Inverse like:

```
$ LPWMG0C Enable,PWM_Gen,PA0,gen_xor;
$ LPWMG2C Enable,Inverse,PA3;
```

### 5.10. WatchDog Timer

The watchdog timer (WDT) is a counter with clock coming from ILRC. WDT can be cleared by power-on-reset or by command **wdreset** at any time. There are four different timeout periods of watchdog timer to be chosen by setting the **misc** register, it is:

- ◆ 8k ILRC clocks period if register misc[1:0]=00 (default)
- ◆ 16k ILRC clocks period if register misc[1:0]=01
- ◆ 64k ILRC clocks period if register misc[1:0]=10
- ◆ 256k ILRC clocks period if register misc[1:0]=11

The frequency of ILRC may drift a lot due to the variation of manufacture, supply voltage and temperature; user should reserve guard band for save operation. Besides, the watchdog period will also be shorter than expected after Reset or Wakeup events. It is suggested to clear WDT by **wdreset** command after these events to ensure enough clock periods before WDT timeout.

When WDT is timeout, PFS123 will be reset to restart the program execution. The relative timing diagram of watchdog timer is shown as Fig.19.

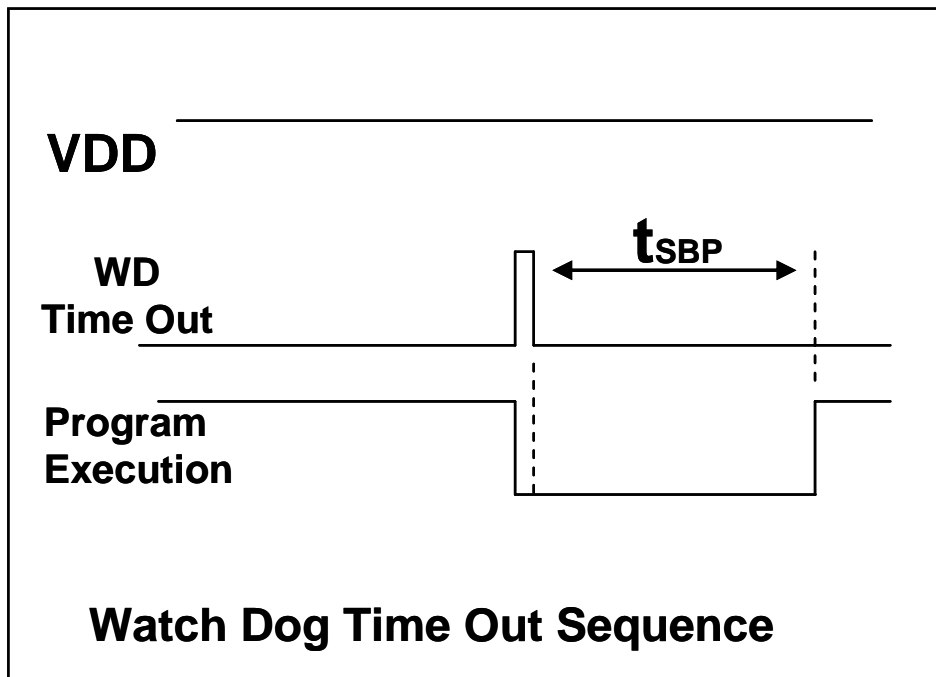

Fig.19: Sequence of Watch Dog Time Out

### 5.11 Interrupt

There are eight interrupt lines for PFS123:

- ◆ External interrupt PA0/PB5      ◆ Timer16 interrupt      ◆ Timer2 interrupt
- ◆ External interrupt PB0/PA4      ◆ GPC interrupt          ◆ Timer3 interrupt
- ◆ ADC interrupt                      ◆ LPWMG interrupt

Every interrupt request line has its own corresponding interrupt control bit to enable or disable it; the hardware diagram of interrupt function is shown as Fig.20. All the interrupt request flags are set by hardware and cleared by writing *intrq* register. When the request flags are set, it can be rising edge, falling edge or both, depending on the setting of register *integs*. All the interrupt request lines are also controlled by *engint* instruction (enable global interrupt) to enable interrupt operation and *disgint* instruction (disable global interrupt) to disable it.

The stack memory for interrupt is shared with data memory and its address is specified by stack register *sp*. Since the program counter is 16 bits width, the bit 0 of stack register *sp* should be kept 0. Moreover, user can use *pushaf* / *popaf* instructions to store or restore the values of *ACC* and *flag* register *to* / *from* stack memory. Since the stack memory is shared with data memory, the stack position and level are arranged by the compiler in Mini-C project. When defining the stack level in ASM project, users should arrange their locations carefully to prevent address conflicts.

Note: the external interrupt source can be switched through Interrupt Src0 or Interrupt Src1 in the Code Option.

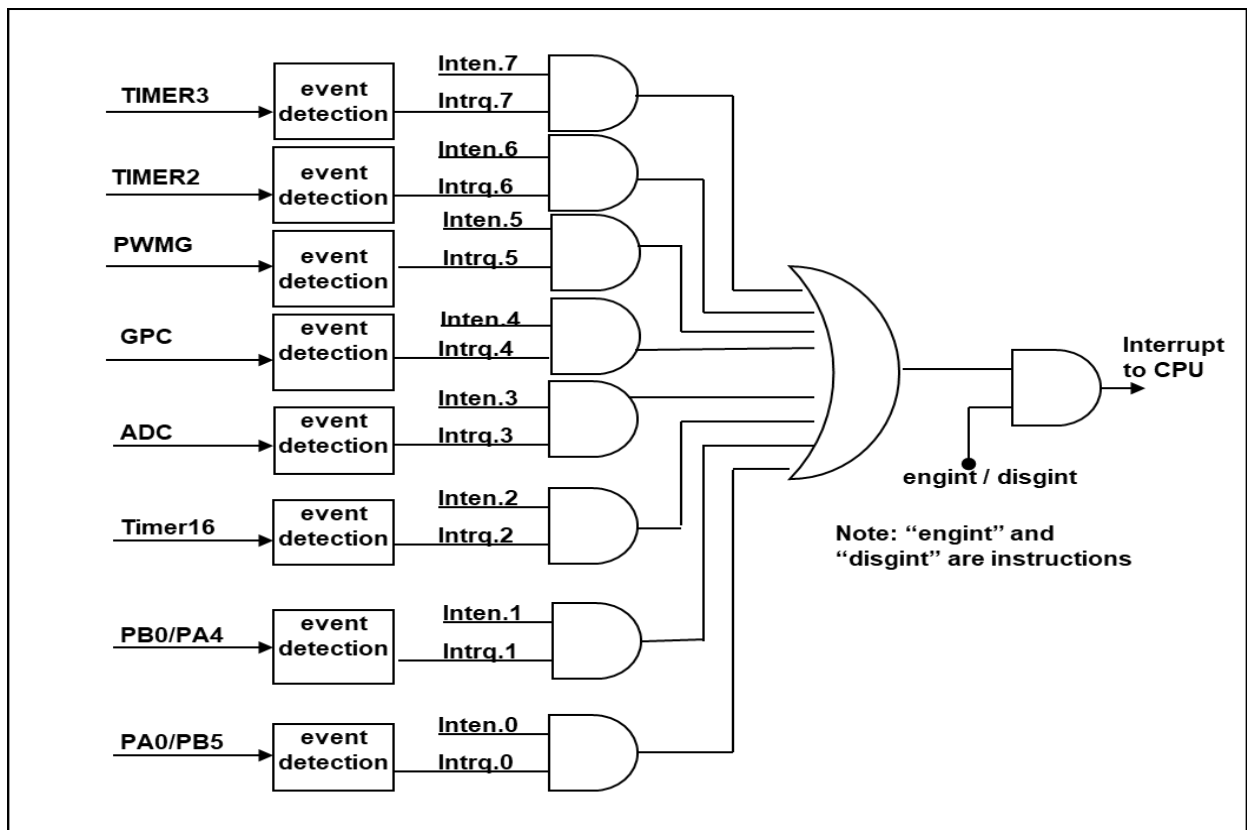

Fig.20: Hardware diagram of interrupt controller

Once the interrupt occurs, its operation will be:

- ◆ The program counter will be stored automatically to the stack memory specified by register **sp**.
- ◆ New **sp** will be updated to **sp+2**.
- ◆ Global interrupt will be disabled automatically.
- ◆ The next instruction will be fetched from address 0x010.

During the interrupt service routine, the interrupt source can be determined by reading the **intrq** register.

Note: Even if INTEN=0, INTRQ will be still triggered by the interrupt source.

After finishing the interrupt service routine and issuing the **reti** instruction to return back, its operation will be:

- ◆ The program counter will be restored automatically from the stack memory specified by register **sp**.
- ◆ New **sp** will be updated to **sp-2**.
- ◆ Global interrupt will be enabled automatically.
- ◆ The next instruction will be the original one before interrupt.

User must reserve enough stack memory for interrupt, two bytes stack memory for one level interrupt and four bytes for two levels interrupt. For interrupt operation, the following sample program shows how to handle the interrupt, noticing that it needs four bytes stack memory to handle interrupt and **pushaf**.

```

void      FPPA0      (void)
{
    ...
    $ INTEN PA0;      // INTEN =1; interrupt request when PA0 level changed
    INTRQ = 0;        // clear INTRQ
    ENGINT            // global interrupt enable
    ...
    DISGINT          // global interrupt disable
    ...
}

void      Interrupt (void)      // interrupt service routine
{
    PUSHAF                // store ALU and FLAG register

    // If INTEN.PA0 will be opened and closed dynamically,
    // user can judge whether INTEN.PA0 =1 or not.
    // Example: If (INTEN.PA0 && INTRQ.PA0) {...}

    // If INTEN.PA0 is always enable,
    // user can omit the INTEN.PA0 judgement to speed up interrupt service routine.

    If (INTRQ.PA0)
    {
        // Here for PA0 interrupt service routine
        INTRQ.PA0 = 0; // Delete corresponding bit (take PA0 for example)
    }
    ...
}

```

```

}
...
// X: INTRQ = 0;           // It is not recommended to use INTRQ = 0 to clear all at the end of the
                           // interrupt service routine.
                           // It may accidentally clear out the interrupts that have just occurred
                           // and are not yet processed.
POPAF                       // restore ALU and FLAG register
}

```

### 5.12 Power-Save and Power-Down

There are three operational modes defined by hardware: ON mode, Power-Save mode and Power-Down modes. ON mode is the state of normal operation with all functions ON, Power-Save mode (“**stopexe**”) is the state to reduce operating current and CPU keeps ready to continue, Power-Down mode (“**stopsys**”) is used to save power deeply. Therefore, Power-Save mode is used in the system which needs low operating power with wake-up periodically and Power-Down mode is used in the system which needs power down deeply with seldom wake-up.

#### 5.12.1 Power-Save mode (“**stopexe**”)

Using “**stopexe**” instruction to enter the Power-Save mode, only system clock is disabled, remaining all the oscillator modules active. For CPU, it stops executing; however, for Timer16, counter keep counting if its clock source is not the system clock. Wake-up from input pins can be considered as a continuation of normal execution, the detail information for Power-Save mode shows below:

- (1) IHRC and EOSC oscillator modules: No change, keep active if it was enabled.
- (2) ILRC oscillator modules: must remain enabled, need to start with ILRC when be wakening up
- (3) System clock: Disable, therefore, CPU stops execution.
- (4) MTP memory is turned off.
- (5) Timer counter: Stop counting if its clock source is system clock or the corresponding oscillator module is disabled; otherwise, it keeps counting. (The Timer contains TM16, TM2, TM3, LPWGM0, LPWGM1, LPWGM2.)
- (6) Wake-up sources:
  - a. IO toggle wake-up: IO toggling in digital input mode ( $PxC$  bit is 1 and  $PxDIER$  bit is 1)
  - b. Timer wake-up: If the clock source of Timer is not the SYSCLK, the system will be awakened when the Timer counter reaches the set value.
  - c. Comparator wake-up: It need setting  $GPCC.7=1$  and  $GPCS.6=1$  to enable the comparator wake-up function at the same time. Please note: the internal 1.20V bandgap reference voltage is not suitable for the comparator wake-up function.

An example shows how to use Timer16 to wake-up from “**stopexe**”:

```

$ T16M    ILRC, /1, BIT8           // Timer16 setting
$ INTEGS  BIT_R, xxx;             // BITx 0 to 1 will trigger (default)

...
WORD     count = 0;
STT16    count;
stopexe;
...

```

The initial counting value of Timer16 is zero and the system will be woken up after the Timer16 counts 256 ILRC clocks.

### 5.12.2 Power-Down mode (“**stopsys**”)

Power-Down mode is the state of deeply power-saving with turning off all the oscillator modules. By using the “**stopsys**” instruction, this chip will be put on Power-Down mode directly. The following shows the internal status of PFS123 detail when “**stopsys**” command is issued:

- (1) All the oscillator modules are turned off.
- (2) MTP memory is turned off.
- (3) The contents of SRAM and registers remain unchanged.
- (4) Wake-up sources: IO toggle in digital mode. (PxDIER bit is 1)

Wake-up from input pins can be considered as a continuation of normal execution. To minimize power consumption, all the I/O pins should be carefully manipulated before entering power-down mode. The reference sample program for power down is shown as below:

```

CLKMD    = 0xF4;    // Change clock from IHRC to ILRC
CLKMD.4 = 0;      // disable IHRC
...
while (1)
{
    STOPSYS;        // enter power-down
    if (...) break; // if wakeup happen and check OK, then return to high speed,
                       // else stay in power-down mode again.
}
CLKMD    = 0x34;    // Change clock from ILRC to IHRC/2

```

### 5.12.3 Wake-up

After entering the Power-Down or Power-Save modes, the PFS123 can be resumed to normal operation by toggling IO pins. Wake-up from timer are available for Power-Save mode ONLY. Table 5 shows the differences in wake-up sources between STOPSYS and STOPEXE.

Differences in wake-up sources between STOPSYS and STOPEXE			
	IO Toggle	Timer wake-up	Comparator wake-up
STOPSYS	Yes	No	No
STOPEXE	Yes	Yes	Yes

Table 5: Differences in wake-up sources between Power-Save mode and Power-Down mode

When using the IO pins to wake-up the PFS123, registers *padier* should be properly set to enable the wake-up function for every corresponding pin. The time for normal wake-up is about 3000 ILRC clocks counting from wake-up event; fast wake-up can be selected to reduce the wake-up time by *misc* register, and the time for fast wake-up is about 45 ILRC clocks from IO toggling.

Suspend mode	Wake-up mode	Wake-up time ( $t_{WUP}$ ) from IO toggle
STOPEXE suspend or STOPSYS suspend	Fast wake-up	$45 * T_{ILRC}$ , Where $T_{ILRC}$ is the time period of ILRC
STOPEXE suspend or STOPSYS suspend	Normal wake-up	$3000 * T_{ILRC}$ , Where $T_{ILRC}$ is the clock period of ILRC

Please notice that when Fast boot-up is selected, no matter which wake-up mode is selected in *misc.5*, the wake-up mode will be forced to be FAST. If Normal boot-up is selected, the wake-up mode is determined by *misc.5*.

### 5.13. IO Pins

All the pins can be independently set into two states output or input by configuring the data registers (*pa*, *pb*, *pc*), control registers (*pac*, *pbc*, *pcc*) and pull-high registers (*paph*, *pbph*, *pcph*). Four pins of them, PB2, PB3, PC0 & PC1, have additional pull-low registers (*pbpl.2*, *pbpl.3*, *pcpl.0*, *pcpl.1*). All these pins have Schmitt-trigger input buffer and output driver with CMOS level. When it is set to output low, the pull-high / pull-low resistor is turned off automatically. If user wants to read the pin state, please notice that it should be set to input mode before reading the data port; if user reads the data port when it is set to output mode, the reading data comes from data register, NOT from IO pad. As an example, Table 6 shows the configuration table of bit 0 of port A. The hardware diagram of IO buffer is also shown as Fig.21.

<i>pa.0</i>	<i>pac.0</i>	<i>paph.0</i>	Description
X	0	0	Input without pull-high resistor
X	0	1	Input with pull-high resistor
0	1	X	Output low without pull-high resistor
1	1	0	Output high without pull-high resistor
1	1	1	Output high with pull-high resistor

Table 6: PA0 Configuration Table



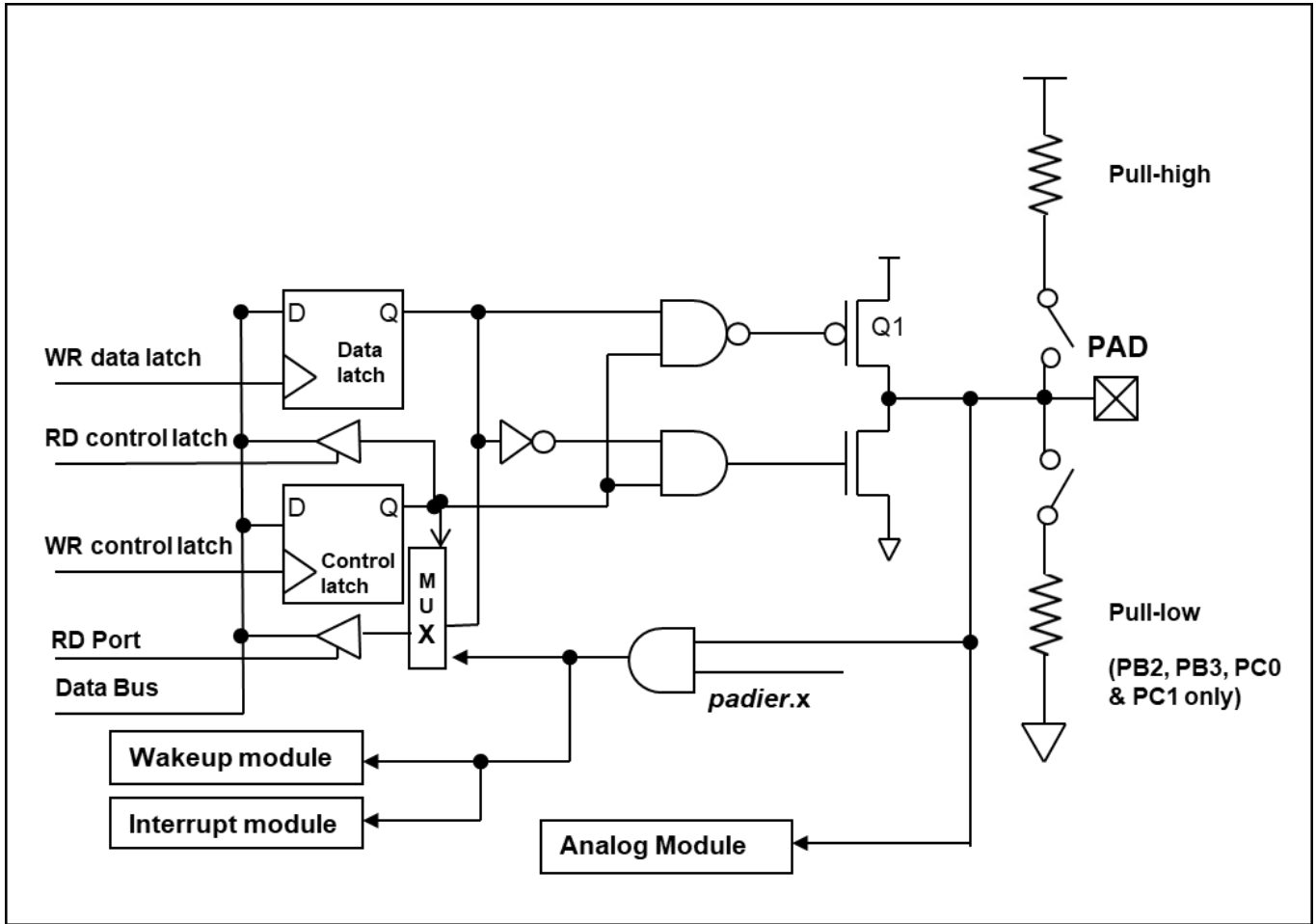

Fig. 21: Hardware diagram of IO buffer

PB4 and PB5 can adjust their drive and sink current by code option **PB4\_PB5\_Drive**.

Other than PA5, all the IO pins have the same structure; PA5 can be open-drain ONLY when setting to output mode (without Q1). The corresponding bits in registers **padier** / **pbdier** / **pcdier** should be set to low to prevent leakage current for those pins are selected to be analog function. When PFS123 is put in power-down or power-save mode, every pin can be used to wake-up system by toggling its state. Therefore, those pins needed to wake-up system must be set to input mode and set the corresponding bits of registers **pxdier** to high. The same reason, **padier.0** should be set high when PA0 is used as external interrupt pin, and so for other external interrupt pins: PB0, PA4 and PB5.

### 5.14. Reset and LVR

#### 5.14.1. Reset

There are many causes to reset the PFS123, once reset is asserted, most of all the registers in PFS123 will be set to default values, system should be restarted once abnormal cases happen, or by jumping program counter to address 0x00.

After a power-on reset or LVR reset occurs, if VDD is greater than VDR (data storage voltage), the value of the data memory will be retained, but if the SRAM is cleared after re-power, the data cannot be retained; if VDD is less than VDR, the data The value of the memory will be turned into an unknown state that is in an indeterminate state.

If a reset occurs, and there is an instruction or syntax to clear SRAM in the program, the previous data will be cleared during program initialization and cannot be retained.

The content will be kept when reset comes from PRSTB pin or WDT timeout.

#### 5.14.2. LVR reset

By code option, there are many different levels of LVR for reset; usually, user selects LVR reset level to be in conjunction with operating frequency and supply voltage.

### 5.15. Analog-to-Digital Conversion (ADC) module

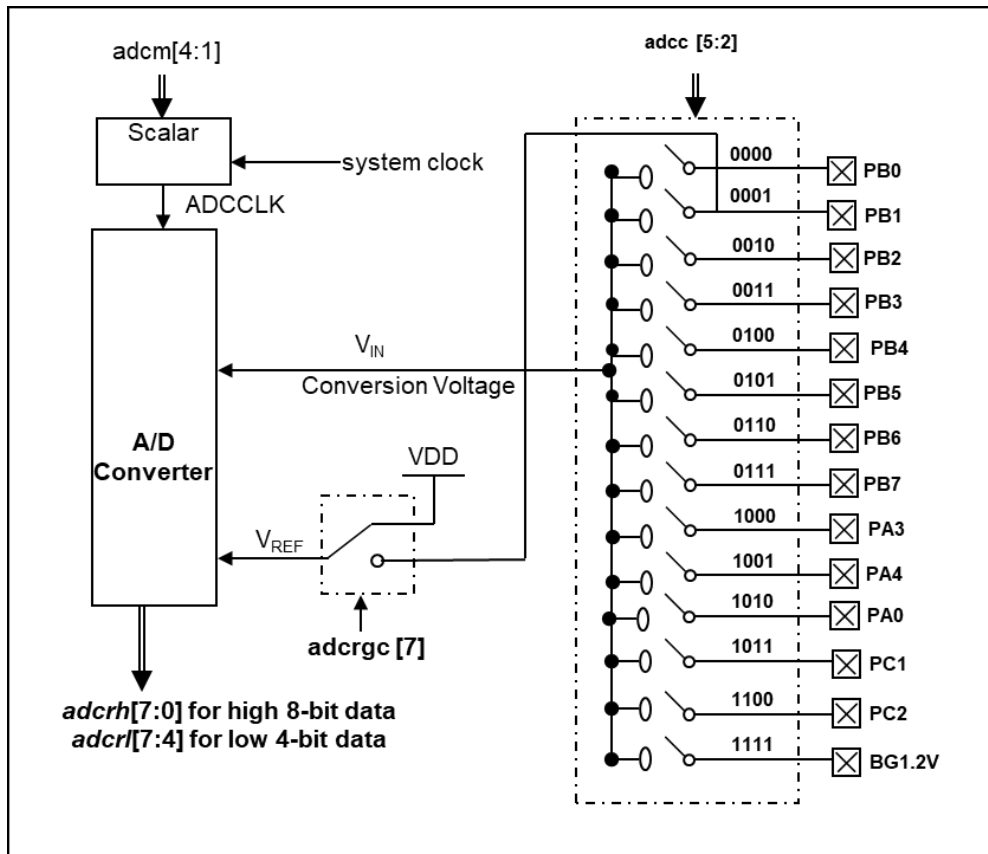

Fig. 22: ADC Block Diagram

There are 8 registers when using the ADC module, which are:

- ◆ ADC Control Register (**adcc**)
- ◆ ADC Regulator Control Register (**adcrhc**)
- ◆ ADC Mode Register (**adcm**)
- ◆ ADC Result Register (**adcrh, adcrl**)
- ◆ Port A/B/C Digital Input Enable Register (**padier, pbdier, pcdier**)

The following steps are required to do the AD conversion procedure:

- (1) Configure the voltage reference high by **adcrhc** register
- (2) Configure the AD conversion clock by **adcm** register
- (3) Configure the pin as analog input by **padier, pbdier, pcdier** register
- (4) Select the ADC input channel by **adcc** register
- (5) Enable the ADC module by **adcc** register
- (6) Execute the AD conversion and check if ADC data is ready  
     set '1' to **adcc.6** to start the conversion and check whether **adcc.6** is '1'
- (7) Read the ADC result registers

### 5.15.1. The input requirement for AD conversion

For the AD conversion to meet its specified accuracy, the charge holding capacitor ( $C_{HOLD}$ ) must be allowed to fully charge to the voltage reference high level and discharge to the voltage reference low level. The analog input model is shown as Fig.23, the signal driving source impedance ( $R_s$ ) and the internal sampling switch impedance ( $R_{ss}$ ) will affect the required time to charge the capacitor  $C_{HOLD}$  directly. The internal sampling switch impedance may vary with ADC supply voltage; the signal driving source impedance will affect accuracy of analog input signal. User must ensure the measured signal is stable before sampling; therefore, the maximum signal driving source impedance is highly dependent on the frequency of signal to be measured. The recommended maximum impedance for analog driving source is about 10KΩ under 500KHz input frequency.

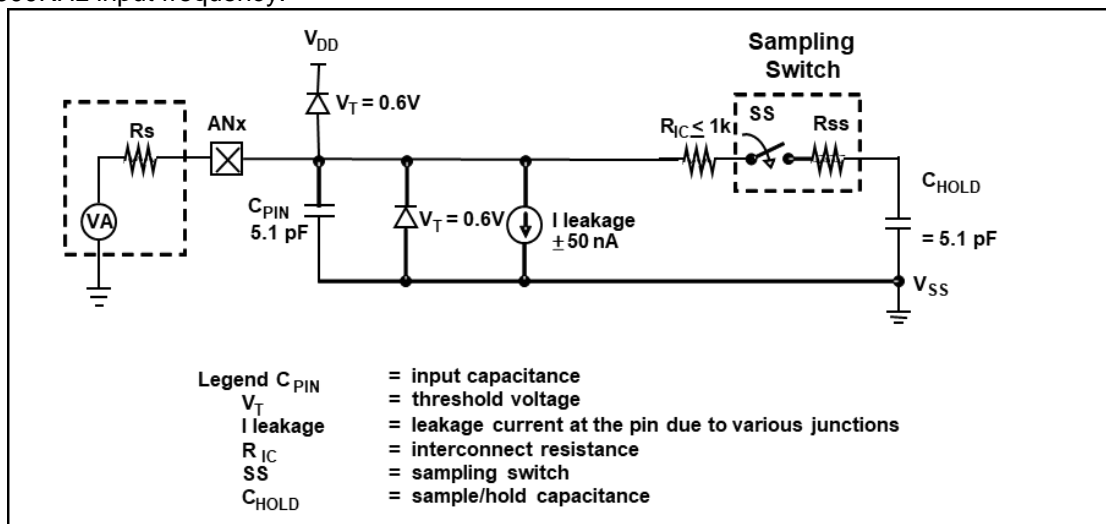

Fig. 23: Analog Input Model

### 5.15.2. Select the reference high voltage

The ADC reference high voltage can be selected via bit[7] of register **adcrhc** and its option can be  $V_{DD}$  or PB1 from external pin.

### 5.15.3. ADC clock selection

Before starting the AD conversion, the minimum signal acquisition time should be met for the selected analog input signal, the selection of ADCLK must be met the minimum signal acquisition time.

The clock of ADC module (ADCLK) can be selected by **adcm** register; there are 8 possible options for ADCLK from  $CLK \div 1$  to  $CLK \div 128$  (CLK is the system clock). Due to the signal acquisition time  $T_{ACQ}$  is one clock period of ADCLK, the ADCLK must meet that requirement. The recommended ADC clock is to operate at 2us.

### 5.15.4. Configure the analog pins

There are 14 analog signals can be selected for AD conversion, 13 analog input signals come from external pins and one is from internal bandgap reference voltage 1.2V. For those external pins defined as analog input, to avoid leakage current from the digital circuit of the shared IO ports, please always remember to disable the digital input function (set the corresponding bit of **padier**, **pbdir** or **pcdir** register to be 0).

Due to the measurement signals of ADC are very small; user should avoid the measured signal to be interfered during the measurement period. Thus, the selected pin should (1) be set to input mode (2) turn off weak pull-high and pull-low resistor (3) set the corresponding pin to analog input by port A/B/C digital input disable register (**padier** / **pbdir** / **pcdir**).

### 5.15.5. Using the ADC

The following example shows how to use ADC with PB0~PB3.

First, defining the selected pins:

```

PBC      =  0B_XXXX_0000;      //  PB0 ~ PB3 as Input
PBPH    =  0B_XXXX_0000;      //  PB0 ~ PB3 without pull-high resistor
PBPL    =  0B_XXXX_00XX;      //  PB2 ~ PB3 without pull-low resistor
PBDIER  =  0B_XXXX_0000;      //  PB0 ~ PB3 digital input is disabled

```

Next, setting **ADCC** register, example as below:

```

$ ADCC Enable, PB3;      //  set PB3 as ADC input
$ ADCC Enable, PB2;      //  set PB2 as ADC input
$ ADCC Enable, PB0;      //  set PB0 as ADC input

```

Next, setting **ADCM** register, example as below:

```

$ ADCM /16;              //  recommend /16 @System Clock=8MHz
$ ADCM /8;               //  recommend /8 @System Clock=4MHz

```

Next, delay 400us, example as below:

```

.Delay 8*400;           //  System Clock=8MHz
.Delay 4*400;           //  System Clock=4MHz

```

Then, start the ADC conversion:

```

AD_START= 1;           //  start ADC conversion
while(!AD_DONE) NULL; //  wait ADC conversion result

```

Finally, it can read ADC result when AD\_DONE is high:

```

WORD      =  Data;      //  two bytes result: ADCRH and ADCRL
Data$1    =  ADCRH;
Data$0    =  ADCRL;
Data      =  Data >> 4;

```

The ADC can be disabled by using the following method:

```

$ ADCC Disable;

```

or

```

ADCC      =  0;

```

### 5.15.6. How to calculate ADC input voltage $V_{IN}$

For PFS122, only VDD but not 1.2V bandgap voltage can be selected as the  $V_{REF}$  of the ADC. When VDD is not regulated, users have to use the reading of 1.2V bandgap voltage to deduce the input voltage ( $V_{IN}$ ) by the ratio of the readings. The principle is as below:

$$V_{BG} / V_{DD} = N_{BG} / 4096 \quad \dots(1)$$

$$V_{IN} / V_{DD} = N_{IN} / 4096 \quad \dots(2)$$

Where,  $V_{IN}$  is the analog input voltage

$V_{BG}$  is the 1.2V bandgap voltage

$N_{IN}$  is the corresponding ADC reading of  $V_{IN}$

$N_{BG}$  is the corresponding ADC reading of  $V_{BG}$

$V_{DD}$  is the  $V_{DD}$  at the measuring instant

4096 is the full swing reading when  $V_{IN}=V_{DD}$  (12bit:  $2^{12} = 4096$ )

(2)/(1) we get:

$$V_{IN}/V_{BG} = N_{IN}/N_{BG}$$

And so,

$$V_{IN} = N_{IN} / N_{BG} * V_{BG}$$

It means users can firstly get the readings for  $V_{IN}$  and  $V_{BG}$  respectively in a very short period that VDD remains unchanged. And then use multiplication and division program module or use look-up table method to finally get the  $V_{IN}$  voltage.

If necessary, please contact FAE for demo code reference.

### 6. IO Registers

#### 6.1. ACC Status Flag Register (*flag*), IO address = 0x00

Bit	Reset	R/W	Description
7 - 4	-	-	Reserved. Please do not use.
3	0	R/W	OV (Overflow Flag). This bit is set to be 1 whenever the sign operation is overflow.
2	0	R/W	AC (Auxiliary Carry Flag). There are two conditions to set this bit, the first one is carry out of low nibble in addition operation and the other one is borrow from the high nibble into low nibble in subtraction operation.
1	0	R/W	C (Carry Flag). There are two conditions to set this bit, the first one is carry out in addition operation, and the other one is borrow in subtraction operation. Carry is also affected by shift with carry instruction.
0	0	R/W	Z (Zero Flag). This bit will be set when the result of arithmetic or logic operation is zero; Otherwise, it is cleared.

#### 6.2. Stack Pointer Register (*sp*), IO address = 0x02

Bit	Reset	R/W	Description
7 - 0	-	R/W	Stack Pointer Register. Read out the current stack pointer, or write to change the stack pointer.

#### 6.3. Clock Mode Register (*clkmd*), IO address = 0x03

Bit	Reset	R/W	Description		
7 - 5	111	R/W	System clock (CLK) selection:		
			Type 0, clkmd[3]=0	Type 1, clkmd[3]=1	
			<table style="width: 100%; border-collapse: collapse;"> <tr> <td style="width: 50%; vertical-align: top;">           000: IHRC÷4            001: IHRC÷2            010: reserved            011: EOSC÷4            100: EOSC÷2            101: EOSC            110: ILRC÷4            111: ILRC (default)         </td> <td style="width: 50%; vertical-align: top;">           000: IHRC÷16            001: IHRC÷8            010: ILRC÷16 (ICE does NOT Support.)            011: IHRC÷32            100: IHRC÷64            101: EOSC÷8            11x: reserved.         </td> </tr> </table>	000: IHRC÷4 001: IHRC÷2 010: reserved 011: EOSC÷4 100: EOSC÷2 101: EOSC 110: ILRC÷4 111: ILRC (default)	000: IHRC÷16 001: IHRC÷8 010: ILRC÷16 (ICE does NOT Support.) 011: IHRC÷32 100: IHRC÷64 101: EOSC÷8 11x: reserved.
000: IHRC÷4 001: IHRC÷2 010: reserved 011: EOSC÷4 100: EOSC÷2 101: EOSC 110: ILRC÷4 111: ILRC (default)	000: IHRC÷16 001: IHRC÷8 010: ILRC÷16 (ICE does NOT Support.) 011: IHRC÷32 100: IHRC÷64 101: EOSC÷8 11x: reserved.				
4	1	R/W	Internal High RC Enable. 0 / 1: disable / enable		
3	0	R/W	Clock Type Select. This bit is used to select the clock type in bit [7:5]. 0 / 1: Type 0 / Type 1.		
2	1	R/W	Internal Low RC Enable. 0 / 1: disable / enable If ILRC is disabled, watchdog timer is also disabled.		
1	1	R/W	Watch Dog Enable. 0 / 1: disable / enable		
0	0	R/W	Pin PA5/PRSTB function. 0 / 1: PA5 / PRSTB.		

### 6.4. Interrupt Enable Register (*inten*), IO address = 0x04

Bit	Reset	R/W	Description
7	0	R/W	Enable interrupt from Timer3. 0 / 1: disable / enable
6	0	R/W	Enable interrupt from Timer2. 0 / 1: disable / enable
5	0	R/W	Enable interrupt from LPWMG. 0 / 1: disable / enable
4	0	R/W	Enable interrupt from comparator. 0 / 1: disable / enable
3	0	R/W	Enable interrupt from ADC. 0 / 1: disable / enable
2	0	R/W	Enable interrupt from Timer16 overflow. 0 / 1: disable / enable
1	0	R/W	Enable interrupt from PB0/PA4. 0 / 1: disable / enable
0	0	R/W	Enable interrupt from PA0/PB5. 0 / 1: disable / enable

### 6.5. Interrupt Request Register (*intrq*), IO address = 0x05

Bit	Reset	R/W	Description
7	-	R/W	Interrupt Request from Timer3, this bit is set by hardware and cleared by software. 0 / 1: No request / Request
6	-	R/W	Interrupt Request from Timer2, this bit is set by hardware and cleared by software. 0 / 1: No request / Request
5	-	R/W	Interrupt Request from LPWMG, this bit is set by hardware and cleared by software. 0 / 1: No request / Request
4	-	R/W	Interrupt Request from comparator, this bit is set by hardware and cleared by software. 0 / 1: No request / Request
3	-	R/W	Interrupt Request from ADC, this bit is set by hardware and cleared by software. 0 / 1: No request / Request
2	-	R/W	Interrupt Request from Timer16, this bit is set by hardware and cleared by software. 0 / 1: No request / Request
1	-	R/W	Interrupt Request from pin PB0/PA4, this bit is set by hardware and cleared by software. 0 / 1: No request / Request
0	-	R/W	Interrupt Request from pin PA0/PB5, this bit is set by hardware and cleared by software. 0 / 1: No Request / request



### 6.6. Timer16 mode Register (*t16m*), IO address = 0x06

Bit	Reset	R/W	Description
7 - 5	000	R/W	Timer16 Clock source selection. 000: disable 001: CLK (system clock) 010: reserved 011: PA4 falling edge (from external pin) 100: IHRC 101: EOSC 110: ILRC 111: PA0 falling edge (from external pin)
4 - 3	00	R/W	Timer16 clock pre-divider. 00: ÷1 01: ÷4 10: ÷16 11: ÷64
2 - 0	000	R/W	Interrupt source selection. Interrupt event happens when the selected bit status is changed. 0 : bit 8 of Timer16 1 : bit 9 of Timer16 2 : bit 10 of Timer16 3 : bit 11 of Timer16 4 : bit 12 of Timer16 5 : bit 13 of Timer16 6 : bit 14 of Timer16 7 : bit 15 of Timer16

### 6.7. External Oscillator setting Register (*eoscr*), IO address = 0x0a

Bit	Reset	R/W	Description
7	0	WO	Enable external crystal oscillator. 0 / 1 : Disable / Enable
6 - 5	00	WO	External crystal oscillator selection. 00 : reserved 01 : Low driving capability, for lower frequency, ex: 32KHz crystal oscillator 10 : Middle driving capability, for middle frequency, ex: 1MHz crystal oscillator 11 : High driving capability, for higher frequency, ex: 4MHz crystal oscillator
4 - 0	-	-	Reserved. Please keep 0 for future compatibility.

### 6.8. Interrupt Edge Select Register (*integs*), IO address = 0x0c

Bit	Reset	R/W	Description
7 - 5	-	-	Reserved.
4	0	WO	Timer16 edge selection. 0 : rising edge of the selected bit to trigger interrupt 1 : falling edge of the selected bit to trigger interrupt
3 - 2	00	WO	PB0/PA4 edge selection. 00: both rising edge and falling edge of the selected bit to trigger interrupt 01: rising edge of the selected bit to trigger interrupt 10: falling edge of the selected bit to trigger interrupt 11: reserved.
1 - 0	00	WO	PA0/PB5 edge selection. 00 : both rising edge and falling edge of the selected bit to trigger interrupt 01 : rising edge of the selected bit to trigger interrupt 10 : falling edge of the selected bit to trigger interrupt 11 : reserved.

### 6.9. Port A Digital Input Enable Register (*padier*), IO address = 0x0d

Bit	Reset	R/W	Description
7	1	WO	Enable PA7 digital input and wake-up event. 1 / 0 : enable / disable This bit should be set to low to prevent leakage current when external crystal oscillator is used. If this bit is set to low, PA7 can NOT be used to wake-up the system.
6	1	WO	Enable PA6 digital input and wake-up event. 1 / 0 : enable / disable This bit should be set to low to prevent leakage current when external crystal oscillator is used. If this bit is set to low, PA6 can NOT be used to wake-up the system.
5	1	WO	Enable PA5 digital input and wake-up event. 1 / 0 : enable / disable This bit can be set to low to disable wake-up from PA5 toggling.
4	1	WO	Enable PA4 digital input, wake-up event and interrupt request. 1 / 0 : enable / disable This bit should be set to low when PA4 is assigned as AD input to prevent leakage current. If this bit is set to low, PA4 can NOT be used to wake-up the system and interrupt request from this pin.
3	1	WO	Enable PA3 digital input and wake-up event. 1 / 0 : enable / disable This bit should be set to low when PA3 is assigned as AD input to prevent leakage current. If this bit is set to low, PA3 can NOT be used to wake-up the system.
2 - 1	-	-	Reserved. (Please keep 00 for future compatibility)
0	1	WO	Enable PA0 digital input, wake-up event and interrupt request. 1 / 0 : enable / disable This bit can be set to low to prevent leakage current when PA0 is assigned as AD input, and to disable wake-up from PA0 toggling and interrupt request from this pin.

### 6.10. Port B Digital Input Enable Register (*pbdier*), IO address = 0x0e

Bit	Reset	R/W	Description
7 - 6	11	WO	Enable PB7~PB6 digital input and wake-up event. 1 / 0 : enable / disable These bits can be set to low to prevent leakage current when PB7~PB6 are assigned as AD inputs. When disable is selected, the wake-up function from these pins are also disabled.
5	1	WO	Enable PB5 digital input, wake-up event and interrupt request. 1 / 0 : enable / disable This bit should be set to low when PB5 is assigned as AD input to prevent leakage current. If this bit is set to low, PB5 can NOT be used to wake-up the system and interrupt request from this pin.
4 - 1	1111	WO	Enable PB4~PB1 digital input and wake-up event. 1 / 0 : enable / disable These bits can be set to low to prevent leakage current when PB4~PB1 are assigned as AD inputs. When disable is selected, the wake-up function from these pins are also disabled.
0	1	WO	Enable PB0 digital input, wake-up event and interrupt request. 1 / 0 : enable / disable This bit should be set to low when PB0 is assigned as AD input to prevent leakage current. If this bit is set to low, PB0 can NOT be used to wake-up the system and interrupt request from this pin.

### 6.11. Port C Digital Input Enable Register (*pcdier*), IO address = 0x0f

Bit	Reset	R/W	Description
7 - 4	-	-	Reserved.
3 - 0	0xF	WO	Enable PC3~PC0 digital input and wake-up event. 1 / 0 : enable / disable These bits can be set to low to prevent leakage current when PC2~PC1 are assigned as AD inputs. When disable is selected, the wake-up function and interrupt requests from these pins are also disabled.

Note: Detail settings please refer to Section 9.2.

### 6.12. Port A Data Register (*pa*), IO address = 0x10

Bit	Reset	R/W	Description
7 - 0	0x00	R/W	Data register for Port A.

### 6.13. Port A Control Register (*pac*), IO address = 0x11

Bit	Reset	R/W	Description
7 - 0	0x00	R/W	Port A control registers. This register is used to define input mode or output mode for each corresponding pin of port A. 0 / 1: input / output <u>Please note that PA5 can be INPUT or OUTPUT LOW ONLY, the output state will be tri-state when PA5 is programmed into output mode with data 1.</u>

### 6.14. Port A Pull-High Register (*paph*), IO address = 0x12

Bit	Reset	R/W	Description
7 - 0	0x00	R/W	Port A pull-high register. This register is used to enable the internal pull-high device on each corresponding pin of port A and this pull high function is active only for input mode. 0 / 1 : disable / enable

### 6.15. Port B Data Register (*pb*), IO address = 0x13

Bit	Reset	R/W	Description
7 - 0	0x00	R/W	Data register for Port B.

### 6.16. Port B Control Register (*pbc*), IO address = 0x14

Bit	Reset	R/W	Description
7 - 0	0x00	R/W	Port B control register. This register is used to define input mode or output mode for each corresponding pin of port B. 0 / 1: input / output

### 6.17. Port B Pull-High Register (*pbph*), IO address = 0x15

Bit	Reset	R/W	Description
7 - 0	0x00	R/W	Port B pull-high register. This register is used to enable the internal pull-high device on each corresponding pin of port B and this pull high function is active only for input mode. 0 / 1 : disable / enable

### 6.18. Port C Data Register (*pc*), IO address = 0x16

Bit	Reset	R/W	Description
7 - 4	-	-	Reserved.
3 - 0	0x00	R/W	Data register for Port C.

### 6.19. Port C Control Register (*pcc*), IO address = 0x17

Bit	Reset	R/W	Description
7 - 4	-	-	Reserved.
3 - 0	0x00	R/W	Port C control register. This register is used to define input mode or output mode for each corresponding pin of port C. 0 / 1: input / output

### 6.20. Port C Pull-High Register (*pcph*), IO address = 0x18

Bit	Reset	R/W	Description
7 - 4	-	-	Reserved.
3 - 0	0x00	R/W	Port C pull-high register. This register is used to enable the internal pull-high device on each corresponding pin of port C and this pull high function is active only for input mode. 0 / 1 : disable / enable

### 6.21. Port B Pull-Low Register (*pbpl*), IO address = 0x19

Bit	Reset	R/W	Description
7 - 4	-	-	Reserved.
3	0	R/W	Port PB3 pull-low register. 0 / 1 : disable / enable
2	0	R/W	Port PB2 pull-low register. 0 / 1 : disable / enable
1 - 0	-	-	Reserved.

### 6.22. Port C Pull-Low Register (*pcpl*), IO address = 0x1a

Bit	Reset	R/W	Description
7 - 2	-	-	Reserved.
1	0	R/W	Port PC1 pull-low register. 0 / 1 : disable / enable
0	0	R/W	Port PC0 pull-low register. 0 / 1 : disable / enable

### 6.23. ADC Control Register (*adcc*), IO address = 0x20

Bit	Reset	R/W	Description
7	0	R/W	Enable ADC function. 0/1: Disable/Enable.
6	0	R/W	ADC process control bit. Write "1" to start conversion Read "1" to indicate the ADC is ready or end of conversion.
5 - 2	0000	R/W	Channel selector. These four bits are used to select input signal for AD conversion. 0000: PB0/AD0, 0001: PB1/AD1, 0010: PB2/AD2, 0011: PB3/AD3, 0100: PB4/AD4, 0101: PB5/AD5, 0110: PB6/AD6, 0111: PB7/AD7, 1000: PA3/AD8, 1001: PA4/AD9, 1010: PA0/AD10, 1011: PC1/AD11, 1100: PC2/AD12, (PA1 for ICE at this address) 1111: (Channel F) Bandgap reference voltage Others: reserved
0 - 1	-	-	Reserved. (keep 0 for future compatibility)

### 6.24. ADC Mode Register (*adcm*), IO address = 0x21

Bit	Reset	R/W	Description
7 - 4	-	-	Reserved. (keep 0 for future compatibility)
3 - 1	000	R/W	ADC clock source selection. 000: CLK (system clock) ÷ 1, 001: CLK (system clock) ÷ 2, 010: CLK (system clock) ÷ 4, 011: CLK (system clock) ÷ 8, 100: CLK (system clock) ÷ 16, 101: CLK (system clock) ÷ 32, 110: CLK (system clock) ÷ 64, 111: CLK (system clock) ÷ 128,
0	-	-	Reserved.

### 6.25. ADC Result High Register (*adcrh*), IO address = 0x22

Bit	Reset	R/W	Description
7 - 0	-	RO	These eight read-only bits will be the bit [11:4] of AD conversion result. The bit 7 of this register is the MSB of ADC result for any resolution.

### 6.26. ADC Result Low Register (*adcr*), IO address = 0x23

Bit	Reset	R/W	Description
7 - 4	-	RO	These four bits will be the bit [3:0] of AD conversion result.
3 - 0	-	-	Reserved

### 6.27. ADC Regulator Control Register (*adcrhc*), IO address = 0x24

Bit	Reset	R/W	Description
7	0	WO	ADC reference high voltage. 0: V <sub>DD</sub> 1: External PIN (PB1)
6 - 0	-	-	Reserved.

### 6.28. MISC Register (*misc*), IO address = 0x26

Bit	Reset	R/W	Description
7 - 6	-	-	Reserved. (keep 0 for future compatibility)
5	0	WO	Enable fast Wake up. Fast wake-up is NOT supported when EOSC is enabled. 0: Normal wake up. The wake-up time is 3000 ILRC clocks (Not for fast boot-up) 1: Fast wake up. The wake-up time is 45 ILRC clocks.
4	0	WO	Enable VDD/2 LCD bias voltage generator 0 / 1 : Disable / Enable (ICE cannot be dynamically switched) If Code Option selects LCD output, but MISC.4 does not set to 1, then the VDD/2 bias cannot be output on the IC. However, the emulator is always OK. Two above phenomena are different.
3	-	-	Reserved.
2	0	WO	Disable LVR function. 0 / 1 : Enable / Disable
1 - 0	00	WO	Watch dog time out period 00: 8k ILRC clock period 01: 16k ILRC clock period 10: 64k ILRC clock period 11: 256k ILRC clock period

### 6.29. Comparator Control Register (*gpcc*), IO address = 0x2b

Bit	Reset	R/W	Description
7	0	R/W	Enable comparator. 0 / 1 : disable / enable When this bit is set to enable, please also set the corresponding analog input pins to be digital disable to prevent IO leakage.
6	-	RO	Comparator result of comparator. 0: plus input < minus input 1: plus input > minus input
5	0	R/W	Select whether the comparator result output will be sampled by TM2_CLK? 0: result output NOT sampled by TM2_CLK 1: result output sampled by TM2_CLK
4	0	R/W	Inverse the polarity of result output of comparator. 0: polarity is NOT inversed. 1: polarity is inversed.
3 - 1	000	R/W	Selection the minus input (-) of comparator. 000 : PA3 001 : PA4 010 : Internal 1.20 volt bandgap reference voltage (not suitable for the comparator wake-up function) 011 : V <sub>internal R</sub> 100 : PB6 101 : PB7 11X: reserved
0	0	R/W	Selection the plus input (+) of comparator. 0 : V <sub>internal R</sub> 1 : PA4

### 6.30. Comparator Selection Register (*gpcs*), IO address = 0x2c

Bit	Reset	R/W	Description
7	0	WO	Comparator output enable (to PA0). 0 / 1 : disable / enable
6	0	WO	Wakeup by comparator enable. (The comparator wakeup effectively when gpcc.6 electrical level changed) Reserved. 0 / 1 : disable / enable
5	0	WO	Selection of high range of comparator.
4	0	WO	Selection of low range of comparator.
3 - 0	0000	WO	Selection the voltage level of comparator. 0000 (lowest) ~ 1111 (highest)

### 6.31. Timer2 Control Register (*tm2c*), IO address = 0x30

Bit	Reset	R/W	Description
7 - 4	0000	R/W	Timer2 clock selection. 0000 : disable 0001 : CLK 0010 : IHRC or IHRC *2 (by code option TMx_source) 0011 : EOSC 0100 : ILRC 0101 : comparator output (ICE does NOT support.) 1000 : PA0 (rising edge) 1001 : ~PA0 (falling edge) 1010 : PB0 (rising edge) 1011 : ~PB0 (falling edge) 1100 : PA4 (rising edge) 1101 : ~PA4 (falling edge) Others: reserved <b>Notice:</b> In ICE mode and IHRC is selected for Timer2 clock, the clock sent to Timer2 does NOT be stopped, Timer2 will keep counting when ICE is in halt state.
3 - 2	00	R/W	Timer2 output selection. 00 : disable 01 : PB2 10 : PA3 11 : PB4
1	0	R/W	Timer2 mode selection. 0 / 1 : period mode / PWM mode
0	0	R/W	Enable to inverse the polarity of Timer2 output. 0 / 1: disable / enable

### 6.32. Timer2 Counter Register (*tm2ct*), IO address = 0x31

Bit	Reset	R/W	Description
7 - 0	0x00	R/W	Bit [7:0] of Timer2 counter register.



### 6.33. Timer2 Scalar Register (*tm2s*), IO address = 0x32

Bit	Reset	R/W	Description
7	0	WO	PWM resolution selection. 0 : 8-bit 1 : 6-bit or 7-bit (by code option TMx_bit)
6 - 5	00	WO	Timer2 clock pre-scalar. 00 : ÷ 1 01 : ÷ 4 10 : ÷ 16 11 : ÷ 64
4 - 0	00000	WO	Timer2 clock scalar.

### 6.34. Timer2 Bound Register (*tm2b*), IO address = 0x33

Bit	Reset	R/W	Description
7 - 0	0x00	WO	Timer2 bound register.

### 6.35. Timer3 Control Register (*tm3c*), IO address = 0x34

Bit	Reset	R/W	Description
7 - 4	0000	R/W	Timer3 clock selection. 0000 : disable 0001 : CLK 0010 : IHRC or IHRC *2 (by code option TMx_source) 0011 : EOSC 0100 : ILRC 0101 : comparator output 1000 : PA0 (rising edge) 1001 : ~PA0 (falling edge) 1010 : PB0 (rising edge) 1011 : ~PB0 (falling edge) 1100 : PA4 (rising edge) 1101 : ~PA4 (falling edge) Others: reserved <b>Notice:</b> In ICE mode and IHRC is selected for Timer3 clock, the clock sent to Timer3 does NOT be stopped, Timer3 will keep counting when ICE is in halt state.
3 - 2	00	R/W	Timer3 output selection. 00 : disable 01 : PB5 10 : PB6 11 : PB7
1	0	R/W	Timer3 mode selection. 0 / 1 : period mode / PWM mode
0	0	R/W	Enable to inverse the polarity of Timer3 output. 0 / 1: disable / enable

### 6.36. Timer3 Counter Register (*tm3ct*), IO address = 0x35

Bit	Reset	R/W	Description
7 - 0	0x00	R/W	Bit [7:0] of Timer2 counter register.

### 6.37. Timer3 Scalar Register (*tm3s*), IO address = 0x36

Bit	Reset	R/W	Description
7	0	WO	PWM resolution selection. 0 : 8-bit 1 : 6-bit or 7-bit (by code option TMx_bit)
6 - 5	00	WO	Timer3 clock pre-scalar. 00 : ÷ 1 01 : ÷ 4 10 : ÷ 16 11 : ÷ 64
4 - 0	00000	WO	Timer3 clock scalar.

### 6.38. Timer3 Bound Register (*tm3b*), IO address = 0x37

Bit	Reset	R/W	Description
7 - 0	0x00	WO	Timer3 bound register.

### 6.39. LPWMG0 control Register (*lpwmg0c*), IO address = 0x40

Bit	Reset	R/W	Description
7	-	-	Reserved.
6	-	RO	Output status of LPWMG0 generator.
5	0	WO	Enable to inverse the polarity of LPWMG0 generator output. 0 / 1: disable / enable.
4	0	WO	LPWMG0 output selection. 0: LPWMG0 Output 1: LPWMG0 XOR LPWMG1 or LPWMG0 OR LPWMG1 (by lpwmg0c.0)
3 - 1	000	R/W	LPWMG0 Output Port Selection 000: LPWMG0 Output Disable 001: LPWMG0 Output to PB5 010: LPWMG0 Output to PC2 011: LPWMG0 Output to PA0 100: LPWMG0 Output to PB4 101: LPWMG0 Output to PB6 (Available if the PB6 is not assigned to output LPWMG1) others: Reserved
0	0	R/W	LPWMG0 output pre- selection. 0: LPWMG0 XOR LPWMG1 1: LPWMG0 OR LPWMG1

### 6.40. LPWMG Clock Register (*lpwmgclk*), IO address = 0x41

Bit	Reset	R/W	Description
7	0	WO	LPWMG Disable/ Enable 0: LPWMG Disable 1: LPWMG Enable
6 - 4	000	WO	LPWMG clock pre-scalar. 000: ÷1 001: ÷2 010: ÷4 011: ÷8 100: ÷16 101: ÷32 110: ÷64 111: ÷128
3 - 1	-	-	Reserved.
0	0	WO	LPWMG clock source selection 0: System Clock 1: IHRC or IHRC*2 (by code option PWM_Source)

### 6.41. LPWMG0 Duty Value High Register (*lpwmg0dth*), IO address = 0x42

Bit	Reset	R/W	Description
7 - 0	-	WO	Bit[10:3] of LPWMG0 Duty.

### 6.42. LPWMG0 Duty Value Low Register (*lpwmg0dtl*), IO address = 0x43

Bit	Reset	R/W	Description
7 - 5	-	WO	Bit[2:0] of LPWMG0 Duty.
4 - 0	-	-	Reserved.

**Note:** It's necessary to write LPWMG0 Duty\_Value Low Register before writing LPWMG0 Duty Value High Register.

### 6.43. LPWMG Counter Upper Bound High Register (*lpwmgcubh*), IO address = 0x44

Bit	Reset	R/W	Description
7 - 0	-	WO	Bit[10:3] of LPWMG Counter Bound.

### 6.44. LPWMG Counter Upper Bound Low Register (*lpwmgcubl*), IO address = 0x45

Bit	Reset	R/W	Description
7 - 6	-	WO	Bit[2:1] of LPWMG Counter Bound.
5 - 0	-	-	Reserved.

### 6.45. LPWMG1 control Register (*lpwmg1c*), IO address = 0x46

Bit	Reset	R/W	Description
7	-	-	Reserved.
6	-	RO	Output status of LPWMG1 generator.
5	0	R/W	Enable to inverse the polarity of LPWMG1 generator output. 0 / 1: disable / enable.
4	0	R/W	LPWMG1 output selection: 0: LPWMG1 1: LPWMG2
3 - 1	000	R/W	LPWMG1 Output Port Selection: 000: LPWMG1 Output Disable 001: LPWMG1 Output to PB6 010: LPWMG1 Output to PC3 011: LPWMG1 Output to PA4 100: LPWMG1 Output to PB7 1xx: Reserved
0	-	R/W	Reserved.

### 6.46. LPWMG1 Duty Value High Register (*lpwmg1dth*), IO address = 0x48

Bit	Reset	R/W	Description
7 - 0	-	WO	Bit[10:3] of LPWMG1 Duty

### 6.47. LPWMG1 Duty Value Low Register (*lpwmg1dtl*), IO address = 0x49

Bit	Reset	R/W	Description
7 - 5	-	WO	Bit[2:0] of LPWMG1 Duty.
4 - 0	-	-	Reserved.

**Note:** It's necessary to write LPWMG1 Duty\_Value Low Register before writing LPWMG1 Duty\_Value High Register.

### 6.48. LPWMG2 control Register (*lpwmg2c*), IO address = 0x4C

Bit	Reset	R/W	Description
7	-	-	Reserved.
6	-	RO	Output status of LPWMG2 generator.
5	0	R/W	Enable to inverse the polarity of LPWMG2 generator output. 0 / 1: disable / enable.
4	0	R/W	LPWMG2 output selection: 0: LPWMG2 1: LPWMG2 ÷2
3 - 1	000	R/W	LPWMG2 Output Port Selection: 000: LPWMG2 Output Disable 001: LPWMG2 Output to PB3 010: LPWMG2 Output to PC0 011: LPWMG2 Output to PA3 100: LPWMG2 Output to PB2 101: LPWMG2 Output to PA5 110: LPWMG2 Output to PB5 (Available if the PB5 is not assigned to output LPWMG0) 111: Reserved
0	-	R/W	Reserved.

### 6.49. LPWMG2 Duty Value High Register (*lpwmg2dth*), IO address = 0x4E

Bit	Reset	R/W	Description
7 - 0	-	WO	Bit[10:3] of LPWMG2 Duty.

### 6.50. LPWMG2 Duty Value Low Register (*lpwmg2dtl*), IO address = 0x4F

Bit	Reset	R/W	Description
7 - 5	-	WO	Bit[2:0] of LPWMG2 Duty.
4 - 0	-	-	Reserved.

**Note:** It's necessary to write LPWMG2 Duty\_Value Low Register before writing LPWMG2 Duty\_Value High Register.

### 7. Instructions

Symbol	Description
<b>ACC</b>	Accumulator (Abbreviation of accumulator)
<b>a</b>	Accumulator (symbol of accumulator in program)
<b>sp</b>	Stack pointer
<b>flag</b>	ACC status flag register
<b>I</b>	Immediate data
<b>&amp;</b>	Logical AND
<b> </b>	Logical OR
<b>←</b>	Movement
<b>^</b>	Exclusive logic OR
<b>+</b>	Add
<b>–</b>	Subtraction
<b>~</b>	NOT (logical complement, 1's complement)
<b>¯</b>	NEG (2's complement)
<b>OV</b>	Overflow (The operational result is out of range in signed 2's complement number system)
<b>Z</b>	Zero (If the result of ALU operation is zero, this bit is set to 1)
<b>C</b>	Carry (The operational result is to have carry out for addition or to borrow carry for subtraction in unsigned number system)
<b>AC</b>	Auxiliary Carry (If there is a carry out from low nibble after the result of ALU operation, this bit is set to 1)
<b>M.n</b>	Only addressed in 0~0x7F (0~127) is allowed

### 7.1. Data Transfer Instructions

<i>mov</i> a, I	<p>Move immediate data into ACC.  Example: <i>mov</i> a, 0x0f;  Result: a ← 0fh;  Affected flags: 『N』 Z 『N』 C 『N』 AC 『N』 OV</p>
<i>mov</i> M, a	<p>Move data from ACC into memory  Example: <i>mov</i> MEM, a;  Result: MEM ← a  Affected flags: 『N』 Z 『N』 C 『N』 AC 『N』 OV</p>
<i>mov</i> a, M	<p>Move data from memory into ACC  Example: <i>mov</i> a, MEM ;  Result: a ← MEM; Flag Z is set when MEM is zero.  Affected flags: 『Y』 Z 『N』 C 『N』 AC 『N』 OV</p>
<i>mov</i> a, IO	<p>Move data from IO into ACC  Example: <i>mov</i> a, pa ;  Result: a ← pa; Flag Z is set when pa is zero.  Affected flags: 『Y』 Z 『N』 C 『N』 AC 『N』 OV</p>
<i>mov</i> IO, a	<p>Move data from ACC into IO  Example: <i>mov</i> pb, a;  Result: pb ← a  Affected flags: 『N』 Z 『N』 C 『N』 AC 『N』 OV</p>
<i>ldtabh</i> index	<p>Load high byte data in OTP program memory to ACC by using index as OTP address. It needs 2T to execute this instruction.  Example: <i>ldtabh</i> index;  Result: a ← {bit 15~8 of OTP [index]};  Affected flags: 『N』 Z 『N』 C 『N』 AC 『N』 OV  Application Example:</p> <pre> ----- word    ROMptr ;           // declare a pointer of ROM in RAM ... mov     a, la@TableA ;     // assign pointer to ROM TableA (LSB) mov     lb@ROMptr, a ;     // save pointer to RAM (LSB) mov     a, ha@TableA ;     // assign pointer to ROM TableA (MSB) mov     hb@ROMptr, a ;     // save pointer to RAM (MSB) ... ldtabh ROMptr ;           // load TableA MSB to ACC (ACC=0X02) ... TableA :    dc    0x0234, 0x0042, 0x0024, 0x0018 ; ----- </pre>

<i>ldtbl</i> index	<p>Load low byte data in OTP to ACC by using index as OTP address. It needs 2T to execute this instruction.</p> <p>Example: <i>ldtbl index</i>;</p> <p>Result: <math>a \leftarrow \{\text{bit7}\sim\text{0 of OTP [index]}\}</math>;</p> <p>Affected flags: 『N』 Z 『N』 C 『N』 AC 『N』 OV</p> <p>Application Example:</p> <hr style="border-top: 1px dashed black;"/> <pre style="font-family: monospace;"> word    ROMptr ;           // declare a pointer of ROM in RAM ... mov     a, la@TableA ;     // assign pointer to ROM TableA (LSB) mov     lb@ROMptr, a ;     // save pointer to RAM (LSB) mov     a, ha@TableA ;     // assign pointer to ROM TableA (MSB) mov     hb@ROMptr, a ;     // save pointer to RAM (MSB) ... ldtbl   ROMptr ;           // load TableA LSB to ACC (ACC=0x34) ... TableA : dc    0x0234, 0x0042, 0x0024, 0x0018 ; </pre> <hr style="border-top: 1px dashed black;"/>
<i>ldt16</i> word	<p>Move 16-bit counting values in Timer16 to memory in word.</p> <p>Example: <i>ldt16 word</i>;</p> <p>Result: <math>\text{word} \leftarrow \text{16-bit timer}</math></p> <p>Affected flags: 『N』 Z 『N』 C 『N』 AC 『N』 OV</p> <p>Application Example:</p> <hr style="border-top: 1px dashed black;"/> <pre style="font-family: monospace;"> word    T16val ;           // declare a RAM word ... clear   lb@ T16val ;       // clear T16val (LSB) clear   hb@ T16val ;       // clear T16val (MSB) stt16   T16val ;           // initial T16 with 0 ... set1    t16m.5 ;           // enable Timer16 ... set0    t16m.5 ;           // disable Timer 16 ldt16   T16val ;           // save the T16 counting value to T16val .... </pre> <hr style="border-top: 1px dashed black;"/>



<i>stt16</i> word	<p>Store 16-bit data from memory in word to Timer16.  Example: <i>stt16</i> word;  Result: 16-bit timer ← word  Affected flags: 『N』 Z 『N』 C 『N』 AC 『N』 OV  Application Example:</p> <hr style="border-top: 1px dashed black;"/> <pre style="margin: 0;">word    T16val ;           // declare a RAM word ... mov     a, 0x34 ; mov     lb@ T16val , a ;    // move 0x34 to T16val (LSB) mov     a, 0x12 ; mov     hb@ T16val , a ;    // move 0x12 to T16val (MSB) stt16   T16val ;           // initial T16 with 0x1234 ...</pre> <hr style="border-top: 1px dashed black;"/>
<i>ldxm a, index</i>	<p>Move data from specified memory to ACC by indirect method. It needs 2T to execute this instruction.  Example: <i>ldxm a, index</i>;  Result: a ← [index], where index is declared by word.  Affected flags: 『N』 Z 『N』 C 『N』 AC 『N』 OV  Application Example:</p> <hr style="border-top: 1px dashed black;"/> <pre style="margin: 0;">word    RAMIndex ;        // declare a RAM pointer ... mov     a, 0x5B ;          // assign pointer to an address (LSB) mov     lb@RAMIndex, a ;   // save pointer to RAM (LSB) mov     a, 0x00 ;          // assign 0x00 to an address (MSB), should be 0 mov     hb@RAMIndex, a ;   // save pointer to RAM (MSB) ... ldxm   a, RAMIndex ;      // move memory data in address 0x5B to ACC</pre> <hr style="border-top: 1px dashed black;"/>
<i>ldxm index, a</i>	<p>Move data from ACC to specified memory by indirect method. It needs 2T to execute this instruction.  Example: <i>ldxm index, a</i>;  Result: [index] ← a; where index is declared by word.  Affected flags: 『N』 Z 『N』 C 『N』 AC 『N』 OV  Application Example:</p> <hr style="border-top: 1px dashed black;"/> <pre style="margin: 0;">word    RAMIndex ;        // declare a RAM pointer ... mov     a, 0x5B ;          // assign pointer to an address (LSB) mov     lb@RAMIndex, a ;   // save pointer to RAM (LSB) mov     a, 0x00 ;          // assign 0x00 to an address (MSB), should be 0 mov     hb@RAMIndex, a ;   // save pointer to RAM (MSB) ... mov     a, 0xA5 ; ldxm   RAMIndex, a ;      // mov 0xA5 to memory in address 0x5B</pre> <hr style="border-top: 1px dashed black;"/>

<i>xch</i> <i>M</i>	<p>Exchange data between ACC and memory  Example: <code>xch MEM ;</code>  Result:    <math>MEM \leftarrow a, a \leftarrow MEM</math>  Affected flags: 『N』 Z 『N』 C 『N』 AC 『N』 OV</p>
<i>pushaf</i>	<p>Move the ACC and flag register to memory that address specified in the stack pointer.  Example: <code>pushaf;</code>  Result:    <math>[sp] \leftarrow \{flag, ACC\};</math>               <math>sp \leftarrow sp + 2 ;</math>  Affected flags: 『N』 Z 『N』 C 『N』 AC 『N』 OV</p> <p>Application Example:</p> <p>-----</p> <pre>.romadr 0x10 ;           // ISR entry address     pushaf ;           // put ACC and flag into stack memory     ...                // ISR program     ...                // ISR program     popaf ;           // restore ACC and flag from stack memory     reti ;</pre> <p>-----</p>
<i>popaf</i>	<p>Restore ACC and flag from the memory which address is specified in the stack pointer.  Example: <code>popaf;</code>  Result:    <math>sp \leftarrow sp - 2 ;</math>               <math>\{Flag, ACC\} \leftarrow [sp] ;</math>  Affected flags: 『Y』 Z 『Y』 C 『Y』 AC 『Y』 OV</p>
<i>nmov</i> <i>M, a</i>	<p>Take the negative logic (2's complement) of ACC to put on memory  Example: <code>mov MEM, a;</code>  Result:    <math>MEM \leftarrow \overline{a}</math>  Affected flags: 『N』 Z 『N』 C 『N』 AC 『N』 OV</p> <p>Application Example:</p> <p>-----</p> <pre>    mov     a, 0xf5 ;           // ACC is 0xf5     nmov   ram9, a;           // ram9 is 0x0b, ACC is 0xf5</pre> <p>-----</p>
<i>nmov</i> <i>a, M</i>	<p>Take the negative logic (2's complement) of memory to put on ACC  Example: <code>mov a, MEM ;</code>  Result:    <math>a \leftarrow \overline{MEM}</math>; Flag Z is set when <math>\overline{MEM}</math> is zero.  Affected flags: 『Y』 Z 『N』 C 『N』 AC 『N』 OV</p> <p>Application Example:</p> <p>-----</p> <pre>    mov     a, 0xf5 ;     mov     ram9, a ;           // ram9 is 0xf5     nmov   a, ram9 ;           // ram9 is 0xf5, ACC is 0x0b</pre> <p>-----</p>

### 7.2. Arithmetic Operation Instructions

<i>add</i> a, l	Add immediate data with ACC, then put result into ACC Example: <i>add</i> a, 0x0f ; Result: $a \leftarrow a + 0fh$ Affected flags: 『Y』 Z 『Y』 C 『Y』 AC 『Y』 OV
<i>add</i> a, M	Add data in memory with ACC, then put result into ACC Example: <i>add</i> a, MEM ; Result: $a \leftarrow a + MEM$ Affected flags: 『Y』 Z 『Y』 C 『Y』 AC 『Y』 OV
<i>add</i> M, a	Add data in memory with ACC, then put result into memory Example: <i>add</i> MEM, a ; Result: $MEM \leftarrow a + MEM$ Affected flags: 『Y』 Z 『Y』 C 『Y』 AC 『Y』 OV
<i>addc</i> a, M	Add data in memory with ACC and carry bit, then put result into ACC Example: <i>addc</i> a, MEM ; Result: $a \leftarrow a + MEM + C$ Affected flags: 『Y』 Z 『Y』 C 『Y』 AC 『Y』 OV
<i>addc</i> M, a	Add data in memory with ACC and carry bit, then put result into memory Example: <i>addc</i> MEM, a ; Result: $MEM \leftarrow a + MEM + C$ Affected flags: 『Y』 Z 『Y』 C 『Y』 AC 『Y』 OV
<i>addc</i> a	Add carry with ACC, then put result into ACC Example: <i>addc</i> a ; Result: $a \leftarrow a + C$ Affected flags: 『Y』 Z 『Y』 C 『Y』 AC 『Y』 OV
<i>addc</i> M	Add carry with memory, then put result into memory Example: <i>addc</i> MEM ; Result: $MEM \leftarrow MEM + C$ Affected flags: 『Y』 Z 『Y』 C 『Y』 AC 『Y』 OV
<i>nadd</i> a, M	Add negative logic (2's complement) of ACC with memory Example: <i>nadd</i> a, MEM ; Result: $a \leftarrow \overline{a} + MEM$ Affected flags: 『Y』 Z 『Y』 C 『Y』 AC 『Y』 OV
<i>nadd</i> M, a	Add negative logic (2's complement) of memory with ACC Example: <i>nadd</i> MEM, a ; Result: $MEM \leftarrow \overline{MEM} + a$ Affected flags: 『Y』 Z 『Y』 C 『Y』 AC 『Y』 OV
<i>sub</i> a, l	Subtraction immediate data from ACC, then put result into ACC Example: <i>sub</i> a, 0x0f ; Result: $a \leftarrow a - 0fh$ ( $a + [2's \text{ complement of } 0fh]$ ) Affected flags: 『Y』 Z 『Y』 C 『Y』 AC 『Y』 OV
<i>sub</i> a, M	Subtraction data in memory from ACC, then put result into ACC Example: <i>sub</i> a, MEM ; Result: $a \leftarrow a - MEM$ ( $a + [2's \text{ complement of } M]$ ) Affected flags: 『Y』 Z 『Y』 C 『Y』 AC 『Y』 OV

<i>sub</i> M, a	<p>Subtraction data in ACC from memory, then put result into memory</p> <p>Example: <i>sub</i> MEM, a;</p> <p>Result: <math>MEM \leftarrow MEM - a</math> ( <math>MEM + [2\text{'s complement of } a]</math> )</p> <p>Affected flags: 『Y』 Z 『Y』 C 『Y』 AC 『Y』 OV</p>
<i>subc</i> a, M	<p>Subtraction data in memory and carry from ACC, then put result into ACC</p> <p>Example: <i>subc</i> a, MEM;</p> <p>Result: <math>a \leftarrow a - MEM - C</math></p> <p>Affected flags: 『Y』 Z 『Y』 C 『Y』 AC 『Y』 OV</p>
<i>subc</i> M, a	<p>Subtraction ACC and carry bit from memory, then put result into memory</p> <p>Example: <i>subc</i> MEM, a ;</p> <p>Result: <math>MEM \leftarrow MEM - a - C</math></p> <p>Affected flags: 『Y』 Z 『Y』 C 『Y』 AC 『Y』 OV</p>
<i>subc</i> a	<p>Subtraction carry from ACC, then put result into ACC</p> <p>Example: <i>subc</i> a;</p> <p>Result: <math>a \leftarrow a - C</math></p> <p>Affected flags: 『Y』 Z 『Y』 C 『Y』 AC 『Y』 OV</p>
<i>subc</i> M	<p>Subtraction carry from the content of memory, then put result into memory</p> <p>Example: <i>subc</i> MEM;</p> <p>Result: <math>MEM \leftarrow MEM - C</math></p> <p>Affected flags: 『Y』 Z 『Y』 C 『Y』 AC 『Y』 OV</p>
<i>inc</i> M	<p>Increment the content of memory</p> <p>Example: <i>inc</i> MEM ;</p> <p>Result: <math>MEM \leftarrow MEM + 1</math></p> <p>Affected flags: 『Y』 Z 『Y』 C 『Y』 AC 『Y』 OV</p>
<i>dec</i> M	<p>Decrement the content of memory</p> <p>Example: <i>dec</i> MEM;</p> <p>Result: <math>MEM \leftarrow MEM - 1</math></p> <p>Affected flags: 『Y』 Z 『Y』 C 『Y』 AC 『Y』 OV</p>
<i>clear</i> M	<p>Clear the content of memory</p> <p>Example: <i>clear</i> MEM ;</p> <p>Result: <math>MEM \leftarrow 0</math></p> <p>Affected flags: 『N』 Z 『N』 C 『N』 AC 『N』 OV</p>

### 7.3. Shift Operation Instructions

<i>sr a</i>	<p>Shift right of ACC, shift 0 to bit 7</p> <p>Example: <i>sr a</i> ;</p> <p>Result: <math>a(0, b7, b6, b5, b4, b3, b2, b1) \leftarrow a(b7, b6, b5, b4, b3, b2, b1, b0)</math>, <math>C \leftarrow a(b0)</math></p> <p>Affected flags: 『N』 Z 『Y』 C 『N』 AC 『N』 OV</p>
<i>src a</i>	<p>Shift right of ACC with carry bit 7 to flag</p> <p>Example: <i>src a</i> ;</p> <p>Result: <math>a(c, b7, b6, b5, b4, b3, b2, b1) \leftarrow a(b7, b6, b5, b4, b3, b2, b1, b0)</math>, <math>C \leftarrow a(b0)</math></p> <p>Affected flags: 『N』 Z 『Y』 C 『N』 AC 『N』 OV</p>
<i>sr M</i>	<p>Shift right the content of memory, shift 0 to bit 7</p> <p>Example: <i>sr MEM</i> ;</p> <p>Result: <math>MEM(0, b7, b6, b5, b4, b3, b2, b1) \leftarrow MEM(b7, b6, b5, b4, b3, b2, b1, b0)</math>, <math>C \leftarrow MEM(b0)</math></p> <p>Affected flags: 『N』 Z 『Y』 C 『N』 AC 『N』 OV</p>
<i>src M</i>	<p>Shift right of memory with carry bit 7 to flag</p> <p>Example: <i>src MEM</i> ;</p> <p>Result: <math>MEM(c, b7, b6, b5, b4, b3, b2, b1) \leftarrow MEM(b7, b6, b5, b4, b3, b2, b1, b0)</math>, <math>C \leftarrow MEM(b0)</math></p> <p>Affected flags: 『N』 Z 『Y』 C 『N』 AC 『N』 OV</p>
<i>sl a</i>	<p>Shift left of ACC shift 0 to bit 0</p> <p>Example: <i>sl a</i> ;</p> <p>Result: <math>a(b6, b5, b4, b3, b2, b1, b0, 0) \leftarrow a(b7, b6, b5, b4, b3, b2, b1, b0)</math>, <math>C \leftarrow a(b7)</math></p> <p>Affected flags: 『N』 Z 『Y』 C 『N』 AC 『N』 OV</p>
<i>slc a</i>	<p>Shift left of ACC with carry bit 0 to flag</p> <p>Example: <i>slc a</i> ;</p> <p>Result: <math>a(b6, b5, b4, b3, b2, b1, b0, c) \leftarrow a(b7, b6, b5, b4, b3, b2, b1, b0)</math>, <math>C \leftarrow a(b7)</math></p> <p>Affected flags: 『N』 Z 『Y』 C 『N』 AC 『N』 OV</p>
<i>sl M</i>	<p>Shift left of memory, shift 0 to bit 0</p> <p>Example: <i>sl MEM</i> ;</p> <p>Result: <math>MEM(b6, b5, b4, b3, b2, b1, b0, 0) \leftarrow MEM(b7, b6, b5, b4, b3, b2, b1, b0)</math>, <math>C \leftarrow MEM(b7)</math></p> <p>Affected flags: 『N』 Z 『Y』 C 『N』 AC 『N』 OV</p>
<i>slc M</i>	<p>Shift left of memory with carry bit 0 to flag</p> <p>Example: <i>slc MEM</i> ;</p> <p>Result: <math>MEM(b6, b5, b4, b3, b2, b1, b0, C) \leftarrow MEM(b7, b6, b5, b4, b3, b2, b1, b0)</math>, <math>C \leftarrow MEM(b7)</math></p> <p>Affected flags: 『N』 Z 『Y』 C 『N』 AC 『N』 OV</p>
<i>swap a</i>	<p>Swap the high nibble and low nibble of ACC</p> <p>Example: <i>swap a</i> ;</p> <p>Result: <math>a(b3, b2, b1, b0, b7, b6, b5, b4) \leftarrow a(b7, b6, b5, b4, b3, b2, b1, b0)</math></p> <p>Affected flags: 『N』 Z 『N』 C 『N』 AC 『N』 OV</p>

### 7.4. Logic Operation Instructions

<i>and</i> a, I	<p>Perform logic AND on ACC and immediate data, then put result into ACC</p> <p>Example: <i>and</i> a, 0x0f ;</p> <p>Result: <math>a \leftarrow a \&amp; 0fh</math></p> <p>Affected flags: 『Y』 Z 『N』 C 『N』 AC 『N』 OV</p>
<i>and</i> a, M	<p>Perform logic AND on ACC and memory, then put result into ACC</p> <p>Example: <i>and</i> a, RAM10 ;</p> <p>Result: <math>a \leftarrow a \&amp; RAM10</math></p> <p>Affected flags: 『Y』 Z 『N』 C 『N』 AC 『N』 OV</p>
<i>and</i> M, a	<p>Perform logic AND on ACC and memory, then put result into memory</p> <p>Example: <i>and</i> MEM, a ;</p> <p>Result: <math>MEM \leftarrow a \&amp; MEM</math></p> <p>Affected flags: 『Y』 Z 『N』 C 『N』 AC 『N』 OV</p>
<i>or</i> a, I	<p>Perform logic OR on ACC and immediate data, then put result into ACC</p> <p>Example: <i>or</i> a, 0x0f ;</p> <p>Result: <math>a \leftarrow a   0fh</math></p> <p>Affected flags: 『Y』 Z 『N』 C 『N』 AC 『N』 OV</p>
<i>or</i> a, M	<p>Perform logic OR on ACC and memory, then put result into ACC</p> <p>Example: <i>or</i> a, MEM ;</p> <p>Result: <math>a \leftarrow a   MEM</math></p> <p>Affected flags: 『Y』 Z 『N』 C 『N』 AC 『N』 OV</p>
<i>or</i> M, a	<p>Perform logic OR on ACC and memory, then put result into memory</p> <p>Example: <i>or</i> MEM, a ;</p> <p>Result: <math>MEM \leftarrow a   MEM</math></p> <p>Affected flags: 『Y』 Z 『N』 C 『N』 AC 『N』 OV</p>
<i>xor</i> a, I	<p>Perform logic XOR on ACC and immediate data, then put result into ACC</p> <p>Example: <i>xor</i> a, 0x0f ;</p> <p>Result: <math>a \leftarrow a \wedge 0fh</math></p> <p>Affected flags: 『Y』 Z 『N』 C 『N』 AC 『N』 OV</p>
<i>xor</i> IO, a	<p>Perform logic XOR on ACC and IO register, then put result into IO register</p> <p>Example: <i>xor</i> pa, a ;</p> <p>Result: <math>pa \leftarrow a \wedge pa</math> ; // pa is the data register of port A</p> <p>Affected flags: 『N』 Z 『N』 C 『N』 AC 『N』 OV</p>
<i>xor</i> a, M	<p>Perform logic XOR on ACC and memory, then put result into ACC</p> <p>Example: <i>xor</i> a, MEM ;</p> <p>Result: <math>a \leftarrow a \wedge RAM10</math></p> <p>Affected flags: 『Y』 Z 『N』 C 『N』 AC 『N』 OV</p>
<i>xor</i> M, a	<p>Perform logic XOR on ACC and memory, then put result into memory</p> <p>Example: <i>xor</i> MEM, a ;</p> <p>Result: <math>MEM \leftarrow a \wedge MEM</math></p> <p>Affected flags: 『Y』 Z 『N』 C 『N』 AC 『N』 OV</p>

<i>not</i> a	<p>Perform 1's complement (logical complement) of ACC  Example: <i>not</i> a;  Result: <math>a \leftarrow \sim a</math>  Affected flags: 『Y』 Z 『N』 C 『N』 AC 『N』 OV  Application Example:</p> <hr/> <pre> mov    a, 0x38 ; // ACC=0X38 not    a ;      // ACC=0XC7 </pre> <hr/>
<i>not</i> M	<p>Perform 1's complement (logical complement) of memory  Example: <i>not</i> MEM;  Result: <math>MEM \leftarrow \sim MEM</math>  Affected flags: 『Y』 Z 『N』 C 『N』 AC 『N』 OV  Application Example:</p> <hr/> <pre> mov    a, 0x38 ; mov    mem, a ; // mem = 0x38 not    mem ;    // mem = 0xC7 </pre> <hr/>
<i>neg</i> a	<p>Perform 2's complement of ACC  Example: <i>neg</i> a;  Result: <math>a \leftarrow \overline{a}</math>  Affected flags: 『Y』 Z 『N』 C 『N』 AC 『N』 OV  Application Example:</p> <hr/> <pre> mov    a, 0x38 ; // ACC=0X38 neg    a ;      // ACC=0XC8 </pre> <hr/>
<i>neg</i> M	<p>Perform 2's complement of memory  Example: <i>neg</i> MEM;  Result: <math>MEM \leftarrow \overline{MEM}</math>  Affected flags: 『Y』 Z 『N』 C 『N』 AC 『N』 OV  Application Example:</p> <hr/> <pre> mov    a, 0x38 ; mov    mem, a ; // mem = 0x38 not    mem ;    // mem = 0xC8 </pre> <hr/>

<i>comp</i> a, M	<p>Compare ACC with the content of memory</p> <p>Example: <i>comp a, MEM;</i></p> <p>Result: Flag will be changed by regarding as ( a - MEM )</p> <p>Affected flags: 『Y』 Z 『Y』 C 『Y』 AC 『Y』 OV</p> <p>Application Example:</p> <hr style="border-top: 1px dashed black;"/> <pre> mov    a, 0x38 ; mov    mem, a ; comp   a, mem ; // Z flag is set as 1 mov    a, 0x42 ; mov    mem, a ; mov    a, 0x38 ; comp   a, mem ; // C flag is set as 1 </pre> <hr style="border-top: 1px dashed black;"/>
<i>comp</i> M, a	<p>Compare ACC with the content of memory</p> <p>Example: <i>comp MEM, a;</i></p> <p>Result: Flag will be changed by regarding as ( MEM - a )</p> <p>Affected flags: 『Y』 Z 『Y』 C 『Y』 AC 『Y』 OV</p>

### 7.5Bit Operation Instructions

<i>set0</i> IO.n	<p>Set bit n of IO port to low</p> <p>Example: <i>set0 pa.5 ;</i></p> <p>Result: set bit 5 of port A to low</p> <p>Affected flags: 『N』 Z 『N』 C 『N』 AC 『N』 OV</p>
<i>set1</i> IO.n	<p>Set bit n of IO port to high</p> <p>Example: <i>set1 pb.5 ;</i></p> <p>Result: set bit 5 of port B to high</p> <p>Affected flags: 『N』 Z 『N』 C 『N』 AC 『N』 OV</p>
<i>swapc</i> IO.n	<p>Swap the nth bit of IO port with carry bit</p> <p>Example: <i>swapc IO.0;</i></p> <p>Result: <math>C \leftarrow IO.0, IO.0 \leftarrow C</math></p> <p>When IO.0 is a port to output pin, carry C will be sent to IO.0;</p> <p>When IO.0 is a port from input pin, IO.0 will be sent to carry C;</p> <p>Affected flags: 『N』 Z 『Y』 C 『N』 AC 『N』 OV</p> <p>Application Example1 (serial output) :</p> <hr style="border-top: 1px dashed black;"/> <pre> ... set1   pac.0 ; // set PA.0 as output ... set0   flag.1 ; // C=0 swapc  pa.0 ; // move C to PA.0 (bit operation), PA.0=0 set1   flag.1 ; // C=1 swapc  pa.0 ; // move C to PA.0 (bit operation), PA.0=1 ... </pre>



	<p>-----</p> <p>Application Example2 (serial input) :</p> <p>-----</p> <pre> ... set0    pac.0 ;    // set PA.0 as input ... swapc   pa.0 ;    // read PA.0 to C (bit operation) src     a ;        // shift C to bit 7 of ACC swapc   pa.0 ;    // read PA.0 to C (bit operation) src     a ;        // shift new C to bit 7, old C ... </pre> <p>-----</p>
<i>set0</i> M.n	<p>Set bit n of memory to low</p> <p>Example: <i>set0</i> MEM.5 ;</p> <p>Result: set bit 5 of MEM to low</p> <p>Affected flags: 『N』 Z 『N』 C 『N』 AC 『N』 OV</p>
<i>set1</i> M.n	<p>Set bit n of memory to high</p> <p>Example: <i>set1</i> MEM.5 ;</p> <p>Result: set bit 5 of MEM to high</p> <p>Affected flags: 『N』 Z 『N』 C 『N』 AC 『N』 OV</p>

### 7.6. Conditional Operation Instructions

<i>ceqsn</i> a, I	<p>Compare ACC with immediate data and skip next instruction if both are equal.</p> <p>Flag will be changed like as (<math>a \leftarrow a - I</math>)</p> <p>Example: <i>ceqsn</i> a, 0x55 ;</p> <pre> inc     MEM ; goto   error ; </pre> <p>Result: If a=0x55, then “goto error”; otherwise, “inc MEM”.</p> <p>Affected flags: 『Y』 Z 『Y』 C 『Y』 AC 『Y』 OV</p>
<i>ceqsn</i> a, M	<p>Compare ACC with memory and skip next instruction if both are equal.</p> <p>Flag will be changed like as (<math>a \leftarrow a - M</math>)</p> <p>Example: <i>ceqsn</i> a, MEM;</p> <p>Result: If a=MEM, skip next instruction</p> <p>Affected flags: 『Y』 Z 『Y』 C 『Y』 AC 『Y』 OV</p>
<i>cneqsn</i> a, M	<p>Compare ACC with memory and skip next instruction if both are not equal.</p> <p>Flag will be changed like as (<math>a \leftarrow a - M</math>)</p> <p>Example: <i>cneqsn</i> a, MEM;</p> <p>Result: If a≠MEM, skip next instruction</p> <p>Affected flags: 『Y』 Z 『Y』 C 『Y』 AC 『Y』 OV</p>
<i>cneqsn</i> a, I	<p>Compare ACC with immediate data and skip next instruction if both are no equal.</p> <p>Flag will be changed like as (<math>a \leftarrow a - I</math>)</p> <p>Example: <i>cneqsn</i> a,0x55 ;</p> <pre> inc     MEM ; goto   error ; </pre> <p>Result: If a≠0x55, then “goto error”; Otherwise, “inc MEM”.</p>

	Affected flags: 『Y』 Z 『Y』 C 『Y』 AC 『Y』 OV
<i>t0sn</i> IO.n	Check IO bit and skip next instruction if it's low Example: <i>t0sn</i> pa.5; Result: If bit 5 of port A is low, skip next instruction Affected flags: 『N』 Z 『N』 C 『N』 AC 『N』 OV
<i>t1sn</i> IO.n	Check IO bit and skip next instruction if it's high Example: <i>t1sn</i> pa.5 ; Result: If bit 5 of port A is high, skip next instruction Affected flags: 『N』 Z 『N』 C 『N』 AC 『N』 OV
<i>t0sn</i> M.n	Check memory bit and skip next instruction if it's low Example: <i>t0sn</i> MEM.5 ; Result: If bit 5 of MEM is low, then skip next instruction Affected flags: 『N』 Z 『N』 C 『N』 AC 『N』 OV
<i>t1sn</i> M.n	Check memory bit and skip next instruction if it's high EX: <i>t1sn</i> MEM.5 ; Result: If bit 5 of MEM is high, then skip next instruction Affected flags: 『N』 Z 『N』 C 『N』 AC 『N』 OV
<i>izsn</i> a	Increment ACC and skip next instruction if ACC is zero Example: <i>izsn</i> a; Result: $a \leftarrow a + 1$ , skip next instruction if $a = 0$ Affected flags: 『Y』 Z 『Y』 C 『Y』 AC 『Y』 OV
<i>dzsn</i> a	Decrement ACC and skip next instruction if ACC is zero Example: <i>dzsn</i> a; Result: $A \leftarrow A - 1$ , skip next instruction if $a = 0$ Affected flags: 『Y』 Z 『Y』 C 『Y』 AC 『Y』 OV
<i>izsn</i> M	Increment memory and skip next instruction if memory is zero Example: <i>izsn</i> MEM; Result: $MEM \leftarrow MEM + 1$ , skip next instruction if $MEM = 0$ Affected flags: 『Y』 Z 『Y』 C 『Y』 AC 『Y』 OV
<i>dzsn</i> M	Decrement memory and skip next instruction if memory is zero Example: <i>dzsn</i> MEM; Result: $MEM \leftarrow MEM - 1$ , skip next instruction if $MEM = 0$ Affected flags: 『Y』 Z 『Y』 C 『Y』 AC 『Y』 OV

### 7.7. System control Instructions

<i>call</i> label	<p>Function call, address can be full range address space</p> <p>Example: <i>call</i> function1;</p> <p>Result: [sp] ← pc + 1  pc ← function1  sp ← sp + 2</p> <p>Affected flags: 『N』 Z 『N』 C 『N』 AC 『N』 OV</p>
<i>goto</i> label	<p>Go to specific address which can be full range address space</p> <p>Example: <i>goto</i> error;</p> <p>Result: Go to error and execute program.</p> <p>Affected flags: 『N』 Z 『N』 C 『N』 AC 『N』 OV</p>
<i>ret</i> I	<p>Place immediate data to ACC, then return</p> <p>Example: <i>ret</i> 0x55;</p> <p>Result: A ← 55h  ret ;</p> <p>Affected flags: 『N』 Z 『N』 C 『N』 AC 『N』 OV</p>
<i>ret</i>	<p>Return to program which had function call</p> <p>Example: <i>ret</i>;</p> <p>Result: sp ← sp - 2  pc ← [sp]</p> <p>Affected flags: 『N』 Z 『N』 C 『N』 AC 『N』 OV</p>
<i>reti</i>	<p>Return to program from interrupt service routine. After this command is executed, global interrupt is enabled automatically.</p> <p>Example: <i>reti</i>;</p> <p>Affected flags: 『N』 Z 『N』 C 『N』 AC 『N』 OV</p>
<i>nop</i>	<p>No operation</p> <p>Example: <i>nop</i>;</p> <p>Result: nothing changed</p> <p>Affected flags: 『N』 Z 『N』 C 『N』 AC 『N』 OV</p>
<i>wdreset</i>	<p>Reset Watchdog timer.</p> <p>Example: <i>wdreset</i> ;</p> <p>Result: Reset Watchdog timer.</p> <p>Affected flags: 『N』 Z 『N』 C 『N』 AC 『N』 OV</p>

<i>pcadd a</i>	<p>Next program counter is current program counter plus ACC.          Example: <i>pcadd a</i>;          Result: <math>pc \leftarrow pc + a</math>          Affected flags: 『N』 Z 『N』 C 『N』 AC 『N』 OV          Application Example:</p> <p>-----</p> <pre> ... mov    a, 0x02 ; pcadd  a ;           // PC &lt;- PC+2 goto   err1 ; goto   correct ;    // jump here goto   err2 ; goto   err3 ; ... correct:           // jump here ... </pre> <p>-----</p>
<i>engint</i>	<p>Enable global interrupt enable          Example: <i>engint</i>;          Result: Interrupt request can be sent to CPU          Affected flags: 『N』 Z 『N』 C 『N』 AC 『N』 OV</p>
<i>disgint</i>	<p>Disable global interrupt enable          Example: <i>disgint</i> ;          Result: Interrupt request is blocked from CPU          Affected flags: 『N』 Z 『N』 C 『N』 AC 『N』 OV</p>
<i>stopsys</i>	<p>System halt.          Example: <i>stopsys</i>;          Result: Stop the system clocks and halt the system          Affected flags: 『N』 Z 『N』 C 『N』 AC 『N』 OV</p>
<i>stopexe</i>	<p>CPU halt. The oscillator module is still active to output clock, however, system clock is disabled to save power.          Example: <i>stopexe</i>;          Result: Stop the system clocks and keep oscillator modules active.          Affected flags: 『N』 Z 『N』 C 『N』 AC 『N』 OV</p>
<i>reset</i>	<p>Reset the whole chip, its operation will be same as hardware reset.          Example: <i>reset</i>;          Result: Reset the whole chip.          Affected flags: 『N』 Z 『N』 C 『N』 AC 『N』 OV</p>

### 7.8. Summary of Instructions Execution Cycle

2T		<i>goto, call, idxm, pcadd, ret, reti, ldtabl, ldtabh</i>
2T	Condition is fulfilled.	<i>ceqsn, cneqsn, t0sn, t1sn, dzsn, izsn</i>
1T	Condition is not fulfilled.	
1T		Others

### 7.9. Summary of affected flags by Instructions

Instruction	Z	C	AC	OV	Instruction	Z	C	AC	OV	Instruction	Z	C	AC	OV
<i>mov a, l</i>	-	-	-	-	<i>mov M, a</i>	-	-	-	-	<i>mov a, M</i>	Y	-	-	-
<i>mov a, IO</i>	Y	-	-	-	<i>mov IO, a</i>	-	-	-	-	<i>ldt16 word</i>	-	-	-	-
<i>stt16 word</i>	-	-	-	-	<i>idxm a, index</i>	-	-	-	-	<i>idxm index, a</i>	-	-	-	-
<i>xch M</i>	-	-	-	-	<i>pushaf</i>	-	-	-	-	<i>popaf</i>	Y	Y	Y	Y
<i>add a, l</i>	Y	Y	Y	Y	<i>add a, M</i>	Y	Y	Y	Y	<i>add M, a</i>	Y	Y	Y	Y
<i>addc a, M</i>	Y	Y	Y	Y	<i>addc M, a</i>	Y	Y	Y	Y	<i>addc a</i>	Y	Y	Y	Y
<i>addc M</i>	Y	Y	Y	Y	<i>nadd a, M</i>	Y	Y	Y	Y	<i>nadd M, a</i>	Y	Y	Y	Y
<i>sub a, l</i>	Y	Y	Y	Y	<i>sub a, M</i>	Y	Y	Y	Y	<i>sub M, a</i>	Y	Y	Y	Y
<i>subc a, M</i>	Y	Y	Y	Y	<i>subc M, a</i>	Y	Y	Y	Y	<i>subc a</i>	Y	Y	Y	Y
<i>subc M</i>	Y	Y	Y	Y	<i>inc M</i>	Y	Y	Y	Y	<i>dec M</i>	Y	Y	Y	Y
<i>clear M</i>	-	-	-	-	<i>sr a</i>	-	Y	-	-	<i>src a</i>	-	Y	-	-
<i>sr M</i>	-	Y	-	-	<i>src M</i>	-	Y	-	-	<i>sl a</i>	-	Y	-	-
<i>slc a</i>	-	Y	-	-	<i>sl M</i>	-	Y	-	-	<i>slc M</i>	-	Y	-	-
<i>swap a</i>	-	-	-	-	<i>and a, l</i>	Y	-	-	-	<i>and a, M</i>	Y	-	-	-
<i>and M, a</i>	Y	-	-	-	<i>or a, l</i>	Y	-	-	-	<i>or a, M</i>	Y	-	-	-
<i>or M, a</i>	Y	-	-	-	<i>xor a, l</i>	Y	-	-	-	<i>xor IO, a</i>	-	-	-	-
<i>xor a, M</i>	Y	-	-	-	<i>xor M, a</i>	Y	-	-	-	<i>not a</i>	Y	-	-	-
<i>not M</i>	Y	-	-	-	<i>neg a</i>	Y	-	-	-	<i>neg M</i>	Y	-	-	-
<i>comp a, M</i>	Y	Y	Y	Y	<i>comp M, a</i>	Y	Y	Y	Y	<i>set0 IO.n</i>	-	-	-	-
<i>set1 IO.n</i>	-	-	-	-	<i>set0 M.n</i>	-	-	-	-	<i>set1 M.n</i>	-	-	-	-
<i>swapc IO.n</i>	-	Y	-	-	<i>ceqsn a, l</i>	Y	Y	Y	Y	<i>ceqsn a, M</i>	Y	Y	Y	Y
<i>cneqsn a, M</i>	Y	Y	Y	Y	<i>cneqsn a, l</i>	Y	Y	Y	Y	<i>t0sn IO.n</i>	-	-	-	-
<i>t1sn IO.n</i>	-	-	-	-	<i>t0sn M.n</i>	-	-	-	-	<i>t1sn M.n</i>	-	-	-	-
<i>izsn a</i>	Y	Y	Y	Y	<i>dzsn a</i>	Y	Y	Y	Y	<i>izsn M</i>	Y	Y	Y	Y
<i>dzsn M</i>	Y	Y	Y	Y	<i>call label</i>	-	-	-	-	<i>goto label</i>	-	-	-	-
<i>ret l</i>	-	-	-	-	<i>ret</i>	-	-	-	-	<i>reti</i>	-	-	-	-
<i>nop</i>	-	-	-	-	<i>pcadd a</i>	-	-	-	-	<i>engint</i>	-	-	-	-
<i>disgint</i>	-	-	-	-	<i>stopsys</i>	-	-	-	-	<i>stopexe</i>	-	-	-	-
<i>reset</i>	-	-	-	-	<i>wdreset</i>	-	-	-	-	<i>ldtabl index</i>	-	-	-	-
<i>ldtabh index</i>	-	-	-	-	<i>nmov M, a</i>	-	-	-	-	<i>nmov a, M</i>	Y	-	-	-

### 7.10. BIT definition

Bit access of RAM is only available for address from 0x00 to 0x7F.

## 8. Code Options

Option	Selection	Description
Security	Enable	MTP content is protected and program cannot be read back
	Disable	MTP content is not protected so program can be read back
LVR	4.0V	Select LVR = 4.0V
	3.5V	Select LVR = 3.5V
	3.0V	Select LVR = 3.0V
	2.7V	Select LVR = 2.7V
	2.5V	Select LVR = 2.5V
	2.2V	Select LVR = 2.2V
	2.0V	Select LVR = 2.0V
Boot-up_Time	Slow	Please refer to $t_{WUP}$ and $t_{SBP}$ in Section 4.1
	Fast	Please refer to $t_{WUP}$ and $t_{SBP}$ in Section 4.1
Interrupt Src0	PA.0	INTEN/ INTRQ.Bit0 is from PA.0
	PB.5	INTEN/ INTRQ.Bit0 is from PB.5
Interrupt Src1	PB.0	INTEN/ INTRQ.Bit1 is from PB.0
	PA.4	INTEN/ INTRQ.Bit1 is from PA.4
PB4_PB5_Drive	Normal	PB4 & PB5 Drive/ Sink Current is Normal
	Strong	PB4 & PB5 Drive/ Sink Current is Strong (ICE does NOT support.)
Comparator Edge	All_Edge	The comparator will trigger an interrupt on both the rising edge or falling edge
	Rising_Edge	The comparator will trigger an interrupt on the rising edge
	Falling_Edge	The comparator will trigger an interrupt on the falling edge
GPC_PWM	Disable	Comparator does not control all PWM outputs
	Enable	Comparator controls all PWM outputs (ICE does NOT support.)
PWM_Source	16MHZ	When $lpwmgclk.0= 1$ , LPWGM clock source = IHRC = 16MHZ
	32MHZ	When $lpwmgclk.0= 1$ , LPWGM clock source = IHRC*2 = 32MHZ (ICE does NOT support.)
TMx_Source	16MHZ	When $tm2c[7:4]= 0010$ , TM2 clock source = IHRC = 16MHZ When $tm3c[7:4]= 0010$ , TM3 clock source = IHRC = 16MHZ
	32MHZ	When $tm2c[7:4]= 0010$ , TM2 clock source = IHRC*2 = 32MHZ When $tm3c[7:4]= 0010$ , TM3 clock source = IHRC*2 = 32MHZ (ICE does NOT support.)

Option	Selection	Description
TMx_Bit	6 Bit	When tm2s.7=1, TM2 PWM resolution is 6 Bit When tm3s.7=1, TM3 PWM resolution is 6 Bit
	7 Bit	When tm2s.7=1, TM2 PWM resolution is 7 Bit When tm3s.7=1, TM3 PWM resolution is 7 Bit (ICE does NOT support.)

## 9. Special Notes

This chapter is to remind user who use PFS123 series IC in order to avoid frequent errors upon operation.

### 9.1. Using IC

#### 9.1.1. IO pin usage and setting

- (1) IO pin is set to be digital input
  - ◆ When IO is set as digital input, the level of  $V_{ih}$  and  $V_{il}$  would changes with the voltage and temperature. Please follow the minimum value of  $V_{ih}$  and the maximum value of  $V_{il}$ .
  - ◆ The value of internal pull high resistor would also change with the voltage, temperature and pin voltage. It is not the fixed value.
  
- (2) If IO pin is set to be digital input and enable wake-up function
  - ◆ Configure IO pin as input.
  - ◆ Set corresponding bit to "1" in PXDIER.
  - ◆ If those IO pins of PA that are not used, such as PADIER [1:2], it should be set low in order to prevent them from leakage.
  - ◆ The function of PCDIER register of PFS123 series IC is different from the ICE. Detail settings please refer to Section 9.2.
  
- (3) PA5 is set to be output pin
  - ◆ PA5 can be set to be Open-Drain output pin only, output high requires adding pull-high resistor.
  
- (4) PA5 is set to be PRSTB input pin
  - ◆ Configure PA5 as input.
  - ◆ Set CLKMD.0=1 to enable PA5 as PRSTB input pin.
  
- (5) PA5 is set to be input pin and to connect with a push button or a switch by a long wire
  - ◆ Needs to put a  $>33\Omega$  resistor in between PA5 and the long wire.
  - ◆ Avoid using PA5 as input in such application.

- (6) PA7 and PA6 as external crystal oscillator
- ◆ Configure PA7 and PA6 as input
  - ◆ Disable PA7 and PA6 internal pull-up resistor
  - ◆ Configure PADIER register to set PA6 and PA7 as analog input
  - ◆ EOSCR register bit [6:5] selects corresponding crystal oscillator frequency:
    - ◇ 01 : for lower frequency, ex : 32KHz
    - ◇ 10 : for middle frequency, ex : 455KHz, 1MHz
    - ◇ 11 : for higher frequency, ex : 4MHz
  - ◆ Program EOSCR.7 =1 to enable crystal oscillator
  - ◆ Ensure EOSC working well before switching from IHRC or ILRC to EOSC

Note: Please read the PMC-APN013 carefully. According to PMC-APN013, the crystal oscillator should be used reasonably. If the following situations happen to cause IC start-up slowly or non-startup, PADAUK Technology is not responsible for this: the quality of the user's crystal oscillator is not good, the usage conditions are unreasonable, the PCB cleaner leakage current, or the PCB layouts are unreasonable.

### 9.1.2. Interrupt

- (1) When using the interrupt function, the procedure should be:

Step1: Set INTEN register, enable the interrupt control bit

Step2: Clear INTRQ register

Step3: In the main program, using ENGINT to enable CPU interrupt function

Step4: Wait for interrupt. When interrupt occurs, enter to Interrupt Service Routine

Step5: After the Interrupt Service Routine being executed, return to the main program

\* Use DISGINT in the main program to disable all interrupts

\* When interrupt service routine starts, use PUSHAF instruction to save ALU and FLAG register. POPAF instruction is to restore ALU and FLAG register before RETI as below:

```
void Interrupt (void) // Once the interrupt occurs, jump to interrupt service routine
{
    // enter DISGINT status automatically, no more interrupt is
    // accepted

    PUSHAF;
    ...
    POPAF;
} // RETI will be added automatically. After RETI being executed, ENGINT status
// will be restored
```

- (2) INTEN and INTRQ have no initial values. Please set required value before enabling interrupt function.
- (3) There are two sets of external IO pin interrupt source. Every set is decided by code option Interrupt Src0 and Interrupt Src1 corresponding to the unique interrupt pin. Please comply with the *inten / intrq / integs* register when selecting IO pin.



### 9.1.3. System clock switching

System clock can be switched by CLKMD register. Please notice that, NEVER switch the system clock and turn off the original clock source at the same time. For example: When switching from clock A to clock B, please switch to clock B first; and after that turn off the clock A oscillator through CLKMD.

- ◆ Example : Switch system clock from ILRC to IHRC/2  
CLKMD = 0x36; // switch to IHRC, ILRC can not be disabled here  
CLKMD.2 = 0; // ILRC can be disabled at this time
- ◆ **ERROR:** Switch ILRC to IHRC and turn off ILRC simultaneously  
CLKMD = 0x50; // MCU will hang

### 9.1.4. Watchdog

Watchdog is open by default, but the program executes ADJUST\_IC ten, and the watchdog will be closed. To use the watchdog, you need to reconfigure the open. Watchdog will be inactive once ILRC is disabled.

### 9.1.5. TIMER time out

When select \$ INTEGS BIT\_R (default value) and T16M counter BIT8 to generate interrupt, if T16M counts from 0, the first interrupt will occur when the counter reaches to 0x100 (BIT8 from 0 to 1) and the second interrupt will occur when the counter reaches 0x300 (BIT8 from 0 to 1). Therefore, selecting BIT8 as 1 to generate interrupt means that the interrupt occurs every 512 counts. Please notice that if T16M counter is restarted, the next interrupt will occur once Bit8 turns from 0 to 1.

If select \$ INTEGS BIT\_F (BIT triggers from 1 to 0) and T16M counter BIT8 to generate interrupt, the T16M counter changes to an interrupt every 0x200/0x400/0x600/. Please pay attention to two differences with setting INTEGS methods.

### 9.1.6. IHRC

- (1) The IHRC frequency calibration is performed when IC is programmed by the writer.
- (2) Because the characteristic of the Epoxy Molding Compound (EMC) would some degrees affects the IHRC frequency (either for package or COB), if the calibration is done before molding process, the actual IHRC frequency after molding may be deviated or becomes out of spec. Normally, the frequency is getting slower a bit.
- (3) It usually happens in COB package or Quick Turnover Programming (QTP). And PADAUK would not take any responsibility for this situation.
- (4) Users can make some compensatory adjustments according to their own experiences. For example, users can set IHRC frequency to be 0.5% ~ 1% higher and aim to get better re-targeting after molding.

### 9.1.7. LVR

LVR level selection is done at compile time. User must select LVR based on the system working frequency and power supply voltage to make the MCU work stably.

The following are Suggestions for setting operating frequency, power supply voltage and LVR level:

SYSCLK	VDD	LVR
2MHz	$\geq 2.2V$	$\geq 2.2V$
4MHz	$\geq 2.5V$	$\geq 2.5V$
8MHz	$\geq 3.5V$	$\geq 3.5V$

Table 7: LVR setting for reference

- (1) The setting of LVR (1.8V ~ 4.0V) will be valid just after successful power-on process.
- (2) User can set MISC.2 as “1” to disable LVR. However,  $V_{DD}$  must be kept as exceeding the lowest working voltage of chip; Otherwise, IC may work abnormally.
- (3) The LVR function will be invalid when IC in stopexe or stopsys mode.

### 9.1.8. Programming Writing

Please use 5S-P-003 to program. 3S-P-002 or older versions do not support programming PFS123.

Jumper connection: Please follow the instruction inside the writer software to connect the jumper.

Please select the following program mode according to the actual situation.

#### Normal Programming Mode

Range of application:

- Single-Chip-Package IC with programming at the writer IC socket or on the handler.
- Multi-Chip-Package(MCP) with PFS123. Be sure its connected IC and devices will not be damaged by the following voltages, and will not clam the following voltages.

#### **The voltage conditions in normal programming mode:**

- (1)  $V_{DD}$  is 7.5V, and the maximum supply current is up to about 20mA.
- (2) PA5 is 8.0V.
- (3) The voltages of other program pins (except GND) are the same as  $V_{DD}$ .

#### **Important Cautions :**

- **You MUST follow the instructions on APN004 and APN011 for programming IC on the handler.**
- **Connecting a 0.01uF capacitor between VDD and GND at the handler port to the IC is always good for suppressing disturbance. But please DO NOT connect with > 0.01uF capacitor, otherwise, programming mode may be fail.**

### Limited-Voltage Programming Mode

Range of application:

- On-Board writing. Its peripheral circuits and devices will not be damaged by the following voltages, and will not clam the following voltages. Please refer to On-Board Writing for more details.
- Multi-Chip-Package(MCP) with PFS123. Please be sure that its connected IC and devices will not be damaged by the following voltages, and will not clam the following voltages.

#### **The voltage conditions in Limited-Voltage programming mode:**

- (1) VDD is 5.0V, and the maximum supply current is up to about 20mA.
- (2) PA5 is 8.0V.
- (3) The voltage of other program pins (except GND) is the same as VDD.

Please select "MTP On-Board VDD Limitation" or "On-Board Program" on the writer screen to enable the limited-voltage programming mode. (Please refer to the file of Writer "5S-P-003 UM").

### On-board Writing

PFS123 can support On-board writing. On-Board Writing is known as the situation that the IC has to be programmed when the IC itself and other peripheral circuits and devices have already been mounted on the PCB. Five wires of 5S-P-003 are used for On-Board Writing: ICPCK, ICPDA, VDD, GND and ICVPP. They are used to connect PA3, PA6, VDD, GND and PA5 of the IC correspondingly.

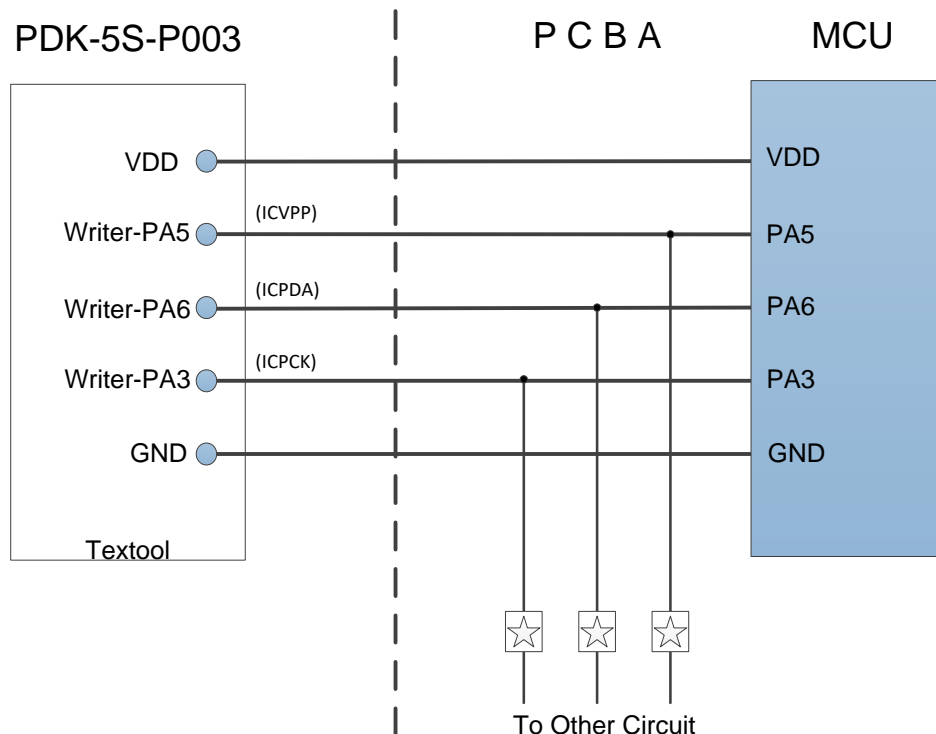

The above figure shows the connection for PFS123 on-board writing. In this figure, ☆ can be either resistors or capacitors. They are used to isolate the programming signal wires from the peripheral circuit. It should be  $\geq 10\text{K}\Omega$  for resistance while  $\leq 220\text{pF}$  for capacitance.

### Notice:

- In general, the limited-voltage programming mode is used in On-board Writing, please refer to the 13.2 for more detail about limited-voltage programming mode.
- Any zener diode  $\leq 5.0\text{V}$ , or any circuitry which clamps the 5.0V to be created SHOULD NOT be connected between VDD and GND of the PCB.
- Any capacitor  $\geq 500\mu\text{F}$  SHOULD NOT be connected between VDD and GND of the PCB.
- In general, the writing signal pins PA3, PA5 and PA6 SHOULD NOT be considered as strong output pins.

## 9.2. Using ICE

- (1) 5S-I-S01/2(B) supports PFS123 MCU emulation, the following items should be noted when using 5S-I-S01/2(B) to emulate PFS123:
- ◆ 5S-I-S01/2(B) doesn't support the instruction NMOV/SWAP/NADD/COMP with RAM.
  - ◆ 5S-I-S01/2(B) doesn't support  $\text{SYSCLK}=\text{ILRC}/16$ .
  - ◆ 5S-I-S01/2(B) doesn't support the dynamic setting of function **misc.4** (Only fix to 0 or 1)
  - ◆ 5S-I-S01/2(B) doesn't support the function **Tm2.gpcrs/Tm3.gpcrs**.
  - ◆ 5S-I-S01/2(B) doesn't support bandgap reference voltage for ADC channel F of ADCRGC [3:2]. Only 1.2V exists and is fixed.
  - ◆ 5S-I-S01/2(B) doesn't support the code options: PB4\_PB5\_Drive, GPC\_PWM, TMx\_source, PWM\_Source and TMx\_bit.
  - ◆ 5S-I-S01/2(B) doesn't support SuLED PWM generation and related registers.
  - ◆ 5S-I-S01/2(B) doesn't support VDD/2 function of PB0.
  - ◆ 5S-I-S01/2(B) has different setting of PC2 and PC1 in **adcc**.
  - ◆ 5S-I-S01/2(B) only supports 240 bytes RAM for data memory.
  - ◆ The PCDIER register of the 5S-I-S01/2(B) emulator is different from the real chip. The PCDIER[0] of the 5S-I-S01/2(B) is used to set PC0~PC3 to be digital input whereas PCDIER[1] is used to set PC4~PC7 to be digital input. It is recommended not to set PCDIER.
  - ◆ When using PB1 in ADCRGC, PA1 must float.
  - ◆ When using GPCC output, PA3 will be influenced.
  - ◆ 5S-I-S01/2(B) doesn't support pull-low simulation.

- ◆ When simulating PWM waveform, please check the waveform during program running. When the ICE is suspended or single-step running, its waveform may be inconsistent with the reality.
- ◆ When using 5S-I-S01/2(B) for simulation, changing the value of tm2ct/tm3ct will affect the duty during timer2/timer3 period mode. But it will not be affected for the actual IC.
- ◆ With 5S-I-S01/2(B) simulation, when fast wake-up is enabled, the watchdog overflow reset time becomes very short. Actually, it has not effect on IC.
- ◆ The ILRC frequency of the 5S-I-S01/2(B) simulator is different from the actual IC and is uncalibrated, with a frequency range of about 34K~38KHz.
- ◆ The power-down command Stopsys does not support the comparator wake-up function. When using 5S-I-S01 / 2 (B), it should be noted that the comparator enable should be set to the off state before entering the power-down mode. If the enable state is turned on, the comparator will be mistakenly awakened.
- ◆ Fast Wakeup time is different from 5S-I-S01/2(B): 128 SysClk, PFS123: 45 ILRC
- ◆ When simulating with 5S-I-S01/2(B), when the ADC module is not enabled, executing the ADCC.6=1; operation will still cause the ADC interrupt flag bit to be set to 1, triggering an interrupt and entering the interrupt function. The actual IC has no effect.
- ◆ Watch dog time out period is different from 5S-I-S01/2(B):

WDT period	5S-I-S01/2(B)	PFS123
misc[1:0]=00	2048 * T <sub>ILRC</sub>	8192 * T <sub>ILRC</sub>
misc[1:0]=01	4096 * T <sub>ILRC</sub>	16384 * T <sub>ILRC</sub>
misc[1:0]=10	16384 * T <sub>ILRC</sub>	65536 * T <sub>ILRC</sub>
misc[1:0]=11	256 * T <sub>ILRC</sub>	262144 * T <sub>ILRC</sub>